

SECTION 2C

FRONT SUSPENSION

CAUTION: Disconnect the negative battery cable before removing or installing any electrical unit or when a tool or equipment could easily come in contact with exposed electrical terminals. Disconnecting this cable will help prevent personal injury and damage to the vehicle. The ignition must also be in LOCK unless otherwise noted.

TABLE OF CONTENTS

Specifications	2C-1	Knuckle Assembly	2C-11
General Specifications	2C-1	Hub and Bearing	2C-15
Fastener Tightening Specifications	2C-2	Control Arm	2C-16
Special Tools	2C-2	Strut Assembly	2C-19
Special Tools Table	2C-2	Crossmember Assembly	2C-21
Diagnosis	2C-3	Unit Repair	2C-24
Strut Dampener	2C-3	Ball Joint	2C-24
Ball Joint and Knuckle	2C-4	Control Arm Bushings	2C-24
Excessive Friction Check	2C-4	Front Strut Assembly	2C-26
Component Locator	2C-6	Knuckle	2C-29
Front Suspension	2C-6	Crossmember	2C-29
Maintenance and Repair	2C-8	General Description and System	
On-Vehicle Service	2C-8	Operation	2C-33
Stabilizer Shaft and Insulators	2C-8	Front Suspension	2C-33
Stabilizer Link	2C-9		

SPECIFICATIONS

GENERAL SPECIFICATIONS



Application	Trim Height
Center of Front Wheel to Bottom of Front Wheel Well	379 mm (15 in.)
Center of Rear Wheel to Bottom of Rear Wheel Well	374 mm (14.7 in.)

FASTENER TIGHTENING SPECIFICATIONS

Application	N•m	Lb•Ft	Lb•In
Ball Joint Pinch Bolt Nuts	90	66	-
Ball Joint to Control Arm Nuts	110	81	-
Control Arm Front Bushing Nuts	140	103	-
Control Arm Rear Bushing Clamp Bolts	75	55	-
Crossmember to Body Front Nuts	145	107	-
Crossmember to Body Rear Bolts	145	107	-
Drive Axle to Hub Caulking Nuts (First Torque)	180	133	-
Drive Axle to Hub Caulking Nuts (Last Torque)	50 + 60°	37 +60°	-
Piston Rod Nuts	70	52	-
Stabilizer Link to Control Arm Nuts	45	33	-
Stabilizer Shaft Clamp Bolts	37	27	-
Stabilizer Shaft to Stabilizer Link Nuts	45	33	-
Steering Knuckle to Strut Assembly Nuts	135	100	-
Strut Assembly to Body Nuts	45	33	-

SPECIAL TOOLS

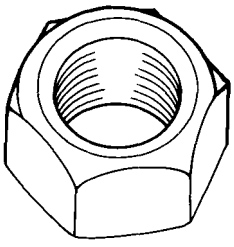
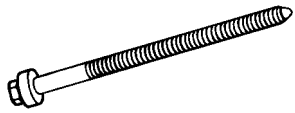
SPECIAL TOOLS TABLE

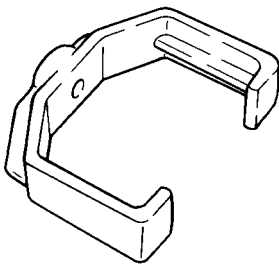
 <p>A106C056</p>	<p>500-20 Hex Nut</p>	 <p>A106C053</p>	<p>J-36661-2 Forcing Screw</p>
 <p>A106C062</p>	<p>DV-005 Front Strut Mount Nut Wrench</p>	 <p>A106C052</p>	<p>J-37105-40 Support Bridge</p>

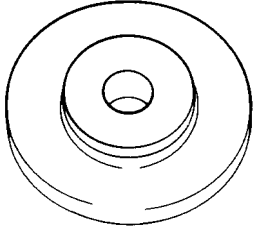
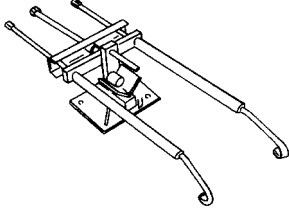
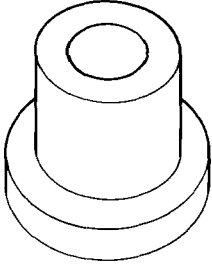
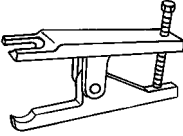
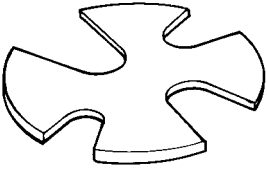
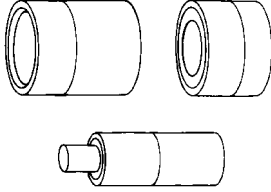
 <p style="text-align: center;">A106C054</p>	<p style="text-align: center;">J-37105-B-2 Bearing Adapter</p>	 <p style="text-align: center;">A106C031</p>	<p style="text-align: center;">KM-329-A Spring Compressor</p>
 <p style="text-align: center;">A106C055</p>	<p style="text-align: center;">J-37105-B-3 Hub Adapter</p>	 <p style="text-align: center;">C106C034</p>	<p style="text-align: center;">KM-333 Ball Joint Remover</p>
 <p style="text-align: center;">A106C030</p>	<p style="text-align: center;">KM-307-B Removal Plate</p>	 <p style="text-align: center;">A106C035</p>	<p style="text-align: center;">KM-508-A Remover/Installer</p>

DIAGNOSIS

STRUT DAMPENER

A strut dampener is basically a shock absorber. However, strut dampeners are easier to extend and retract by hand than are shock absorbers.

Struts Seem Weak

Checks	Action
Check the tire pressures.	Adjust the tire pressures to the specifications on the tire placard.
Check the load conditions under which the vehicle is normally driven.	Consult with the owner to confirm the owner's understanding of normal load conditions.
Check the compression and rebound effectiveness of the strut dampener.	Quickly push down and then lift up on the corner of the bumper nearest the strut dampener being tested. Compare the compression and rebound with those of a similar vehicle that has an acceptable ride quality. Replace the strut dampener, if needed.

Struts Are Noisy

Checks	Action
Check the mountings for looseness or damage.	Tighten the strut dampener mounting nuts. Replace the strut dampener, if needed.
Check the compression and rebound effectiveness of the strut dampener.	Quickly push down and then lift up on the corner of the bumper nearest the strut dampener being tested. Compare the compression and rebound with those of a similar vehicle that has an acceptable ride quality. Replace the strut dampener, if needed.

Leaks

Checks	Action
Check for a slight trace of fluid.	The strut dampener is OK.
Check the seal cover on the fully extended strut.	Replace the strut dampener.
Check for an excessive amount of fluid on the strut dampener.	Replace the strut dampener.

BALL JOINT AND KNUCKLE

Ball Joint Inspection

1. Raise the front of the vehicle to allow the front suspension to hang free.
2. Grasp the tire at the top and the bottom.
3. Move the top of the tire in an in and out motion.
4. Look for any horizontal movement of the knuckle relative to the control arm.
5. Ball joints must be replaced under the following conditions:
 - The joint is loose.
 - The ball seal is cut.
 - The ball stud is disconnected from the knuckle.
 - The ball stud is loose at the knuckle.
 - The ball stud can be twisted in its socket with finger pressure.

Ball Stud Inspection

Make sure to check the tightness of the ball stud in the knuckle boss during each inspection of the ball joint. One way to inspect the ball stud for wear is to shake the wheel and feel for movement of the stud end at the knuckle boss.

Another way to inspect the ball stud for wear is to check the fastener torque at the pinch nut. A loose nut can indicate a stressed stud or a hole in the knuckle boss.

Worn or damaged ball joints and knuckles must be replaced.

EXCESSIVE FRICTION CHECK

Use the following procedure to check for excessive friction in the front suspension:

1. Enlist the help of another technician to lift up on the front bumper, raising the vehicle as high as possible.
2. Slowly release the bumper, allowing the vehicle to assume its normal trim height. See „General Specifications” in this section.
3. Measure the distance from the street level to the center of the bumper.
4. Push down on the bumper, release slowly, and allow the vehicle to assume its normal trim height.
5. Measure the distance from the street level to the center of the bumper.
6. The difference between the two measurements should be less than 12.7 mm (0.5 inch). If the difference exceeds this limit, inspect the control arms, the struts, and the ball joints for damage or wear.

BLANK

COMPONENT LOCATOR

FRONT SUSPENSION

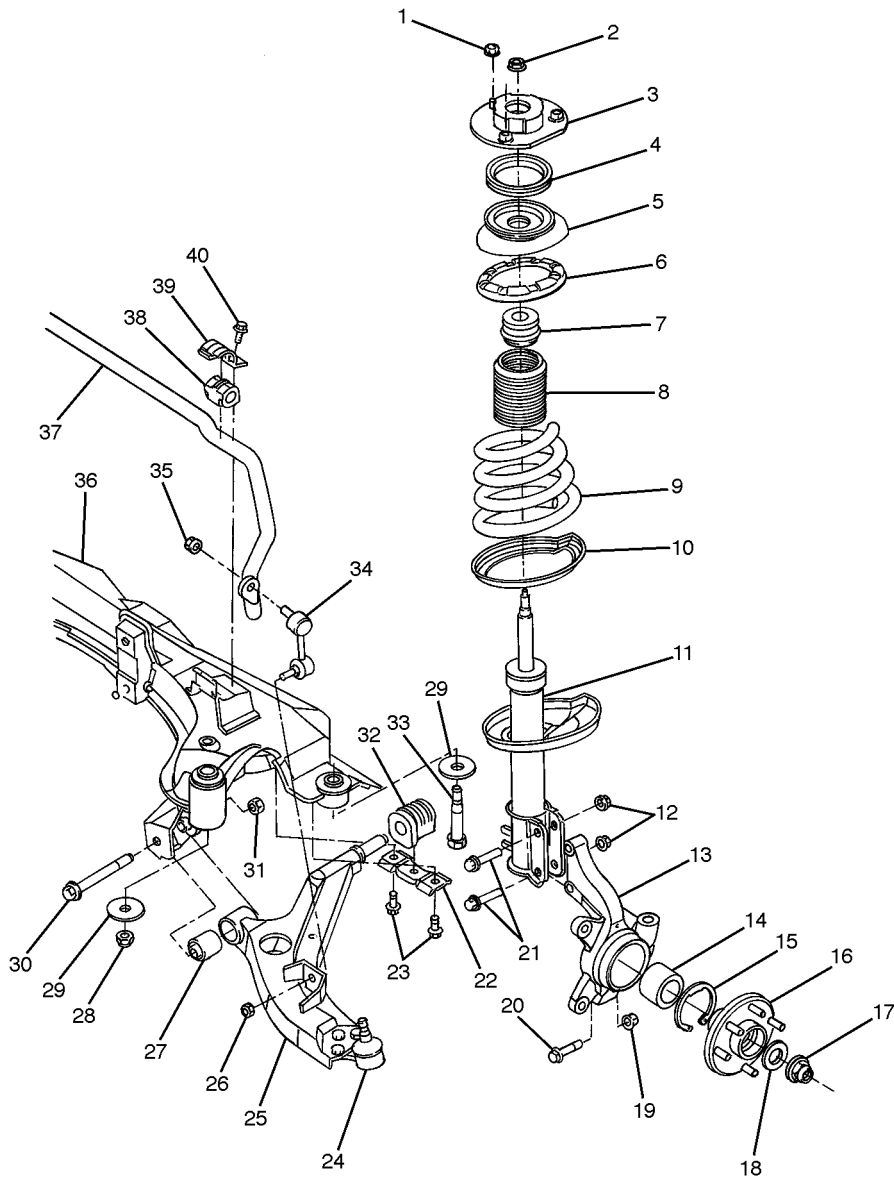

C106C017

- | | | | |
|----|--|----|--|
| 1 | Strut Mount Body Nut | 21 | Steering Knuckle to Strut Assembly Bolts |
| 2 | Piston Rod Nut | 22 | Control Arm Rear Bushing Clamp |
| 3 | Strut Mount | 23 | Control Arm Rear Bushing Clamp Bolts |
| 4 | Strut Mount Bearing | 24 | Ball Joint |
| 5 | Upper Spring Seat | 25 | Control Arm |
| 6 | Upper Spring Insulator | 26 | Stabilizer Link to Control Arm Nut |
| 7 | Hollow Bumper | 27 | Control Arm Front Damping Bushing |
| 8 | Piston Rod Boot | 28 | Crossmember to Body Front Connecting Nut |
| 9 | Front Spring | 29 | Washer |
| 10 | Lower Spring Insulator | 30 | Control Arm Front Bushing Bolt |
| 11 | Strut Dampener | 31 | Control Arm Front Bushing Nut |
| 12 | Steering Knuckle to Strut Assembly Nut | 32 | Control Arm Rear Damping Bushing |
| 13 | Steering Knuckle | 33 | Crossmember to Body Rear Bolt |
| 14 | Front Wheel Bearing | 34 | Stabilizer Link |
| 15 | Outer Snap Ring | 35 | Stabilizer Shaft to Stabilizer Link Nut |
| 16 | Front Hub | 36 | Front Suspension Crossmember |
| 17 | Caulking Nut | 37 | Stabilizer Shaft |
| 18 | Caulking Nut Washer | 38 | Stabilizer Shaft Bushing |
| 19 | Ball Joint Pinch Bolt Nut | 39 | Stabilizer Shaft Bushing Clamp |
| 20 | Ball Joint Pinch Bolt | 40 | Stabilizer Shaft Bushing Clamp Bolt |
-

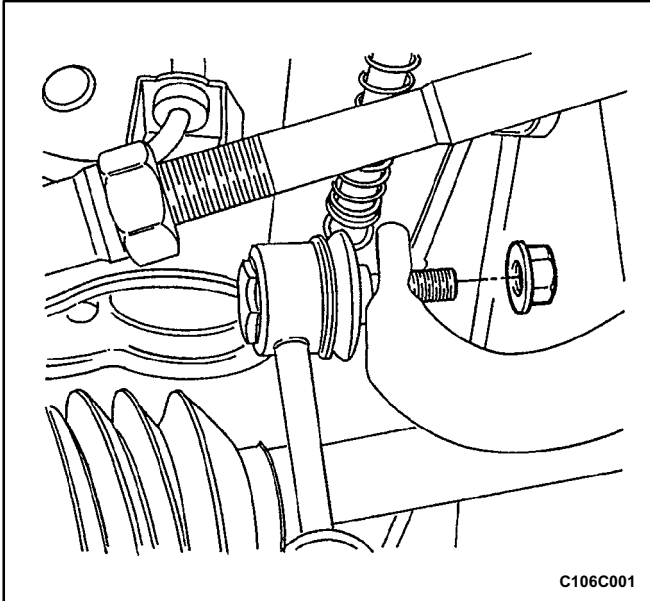

MAINTENANCE AND REPAIR

ON-VEHICLE SERVICE

STABILIZER SHAFT AND INSULATORS

Removal Procedure

1. Raise and suitably support the vehicle.
2. Disconnect the power steering gear. Refer to *Section 6C, Power Steering Gear*.
3. Remove the crossmember front and rear support bolts. Refer to „Crossmember Assembly” in this section.
4. Lower the front crossmember until the stabilizer shaft clamp bolts can be reached.
5. Remove the stabilizer shaft to stabilizer link nuts. Disconnect the stabilizer shaft from the stabilizer links.

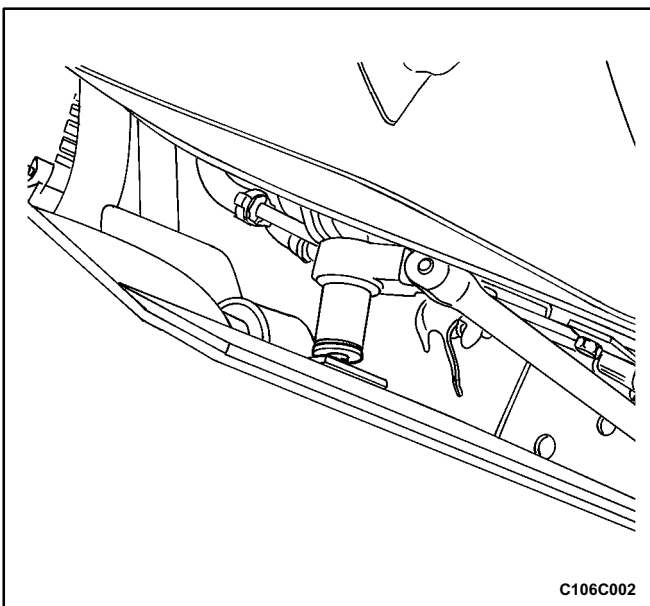

6. Remove the stabilizer shaft clamp bolts.
7. Remove the stabilizer shaft, the stabilizer shaft clamp, and the insulators from the vehicle.

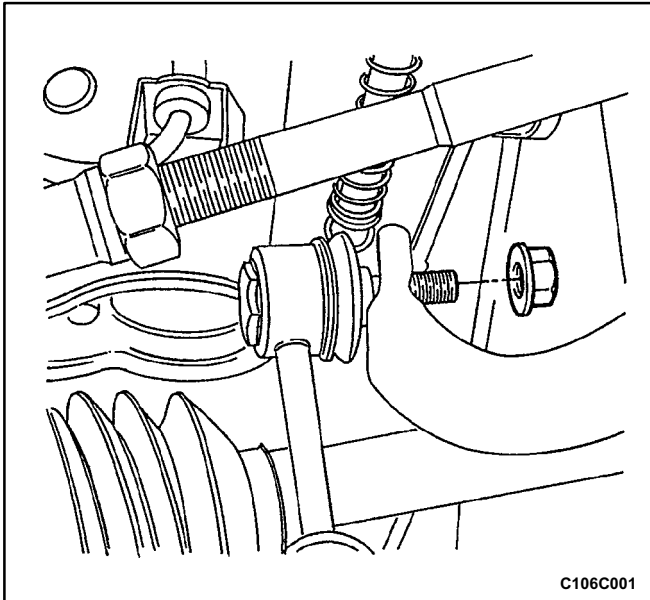

C106C001

Installation Procedure

Important: The weight of the vehicle must be supported by the control arms before the stabilizer link to control arm nuts are tightened. This can be done by lowering the vehicle onto jack stands under the control arms.

1. Install the stabilizer shaft.
2. Install the stabilizer shaft clamps, the stabilizer shaft clamp bolt, and the insulators. Do not tighten the bolt.
3. Install the stabilizer link onto the stabilizer shaft and connect them with the stabilizer shaft to stabilizer link nuts. Do not tighten.

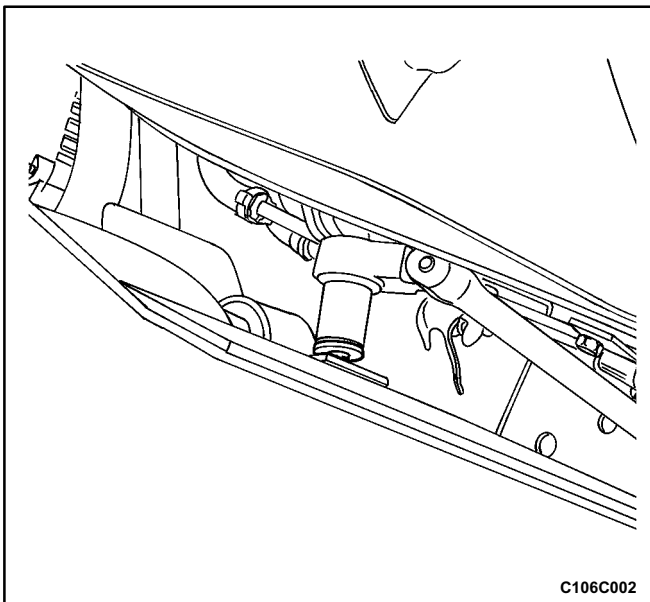

C106C002

Tighten

Tighten the stabilizer shaft clamp bolts to 37 N•m (27 lb•ft).

4. Raise the front crossmember and install the crossmember front and rear support bolts. Refer to „Crossmember Assembly” in this section.
5. Connect the power steering gear. Refer to *Section 6C, Power Steering Gear*.
6. Lower the vehicle so the control arms are supported by jack stands.

Tighten

Tighten the stabilizer shaft to stabilizer link nuts to 45 N•m (33 lb•ft).

7. Remove the jack stands and lower the vehicle.

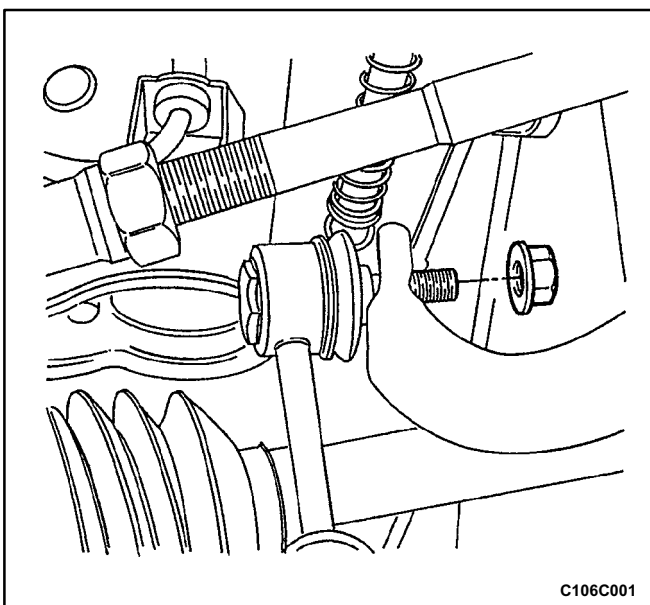

C106C001

STABILIZER LINK

Removal Procedure

1. Raise and suitably support the vehicle.
2. Remove the stabilizer shaft to stabilizer link nut.

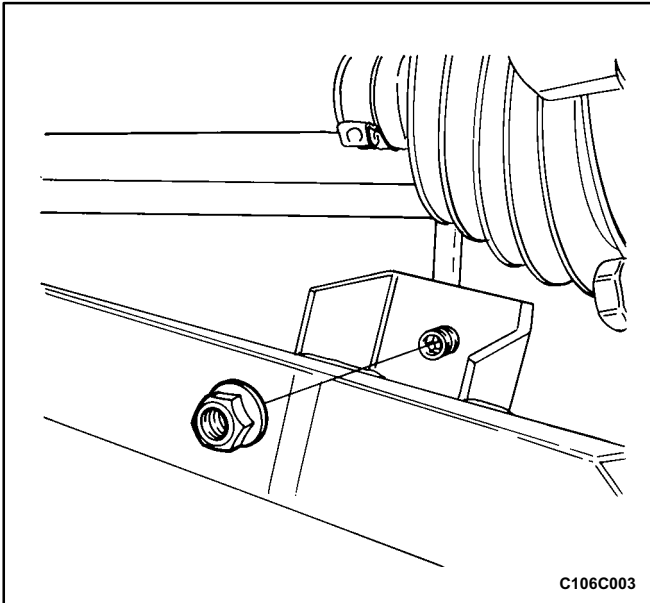

3. Remove the stabilizer link to control arm nut.
4. Remove the stabilizer link.

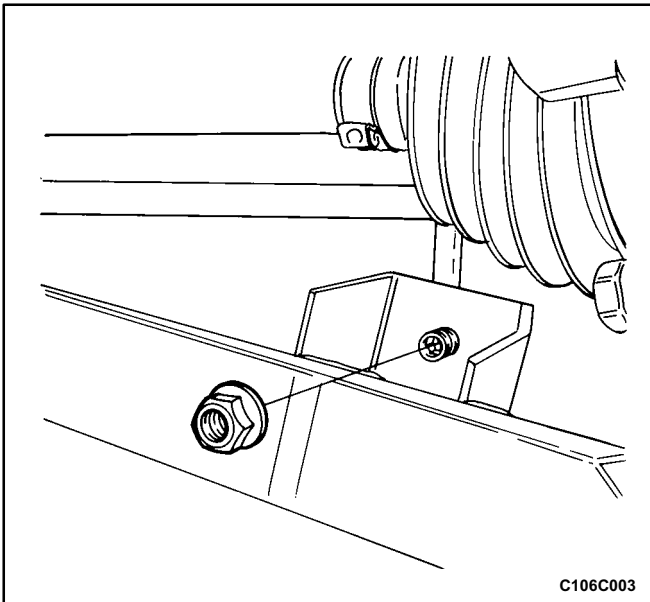

Installation Procedure

Important: The weight of the vehicle must be supported by the control arms before the stabilizer link to control arm nuts or the stabilizer shaft to stabilizer link nuts are tightened. This can be done by lowering the vehicle onto jack stands under the control arms.

1. Install the stabilizer link.
2. Install the stabilizer link to control arm nut.

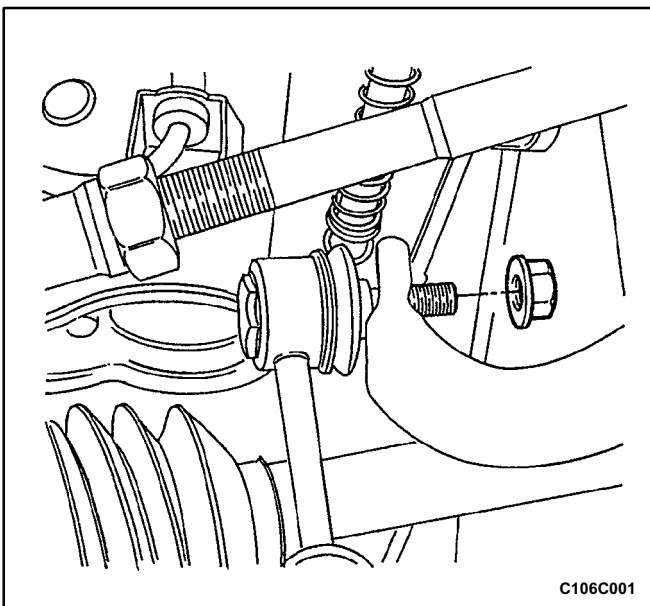

3. Install the stabilizer to stabilizer link nut.
4. Lower the vehicle so the control arms are supported by jack stands.

Tighten

Tighten the stabilizer to stabilizer link nut to 45 N•m (33 lb•ft).

Tighten the stabilizer link to control arm nut to 45 N•m (33 lb•ft).

5. Remove the jack stands and lower the vehicle.

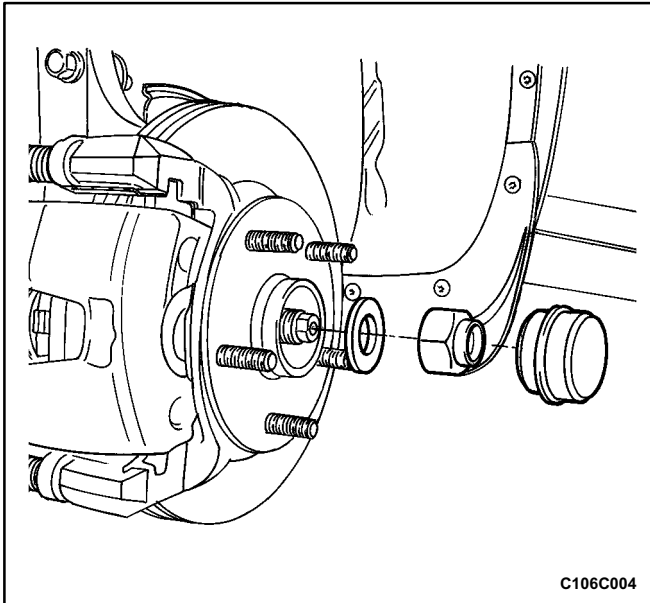

KNUCKLE ASSEMBLY

Tools Required

KM-333 Ball Joint Remover

Removal Procedure

1. Raise and suitably support the vehicle.
2. Remove the wheel. Refer to *Section 2E, Tires and Wheels*.
3. Remove the dust cap the caulking nut, and the washer from the axle shaft.
4. Remove the brake caliper from the rotor and the brake line from the strut assembly. Support the caliper so it does not hang from the hydraulic brake hose. Refer to *Section 4D, Front Disc Brakes*.
5. Remove the outer tie rod from the knuckle assembly. Refer to *Section 6C, Power Steering Gear*.
6. On vehicles equipped with the antilock braking system (ABS), disconnect the ABS speed sensor electrical connection from the knuckle. Refer to *Section 4F, Antilock Brake System and Traction Control System*.

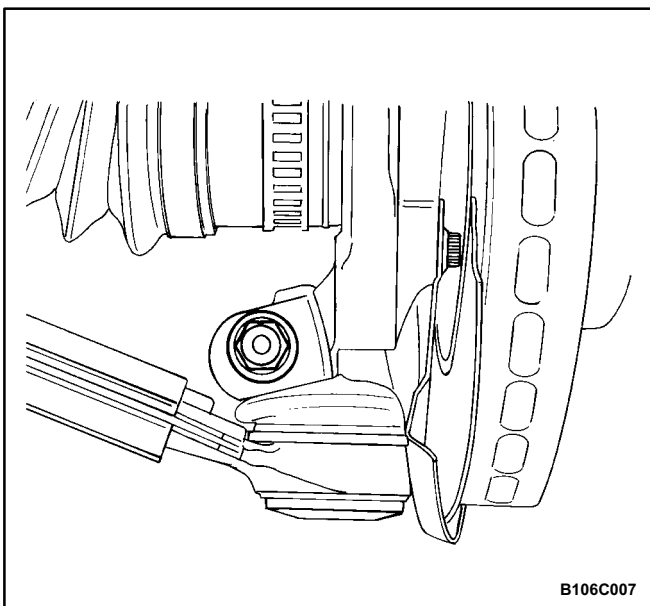

7. Remove the ball joint pinch bolt and the nut.

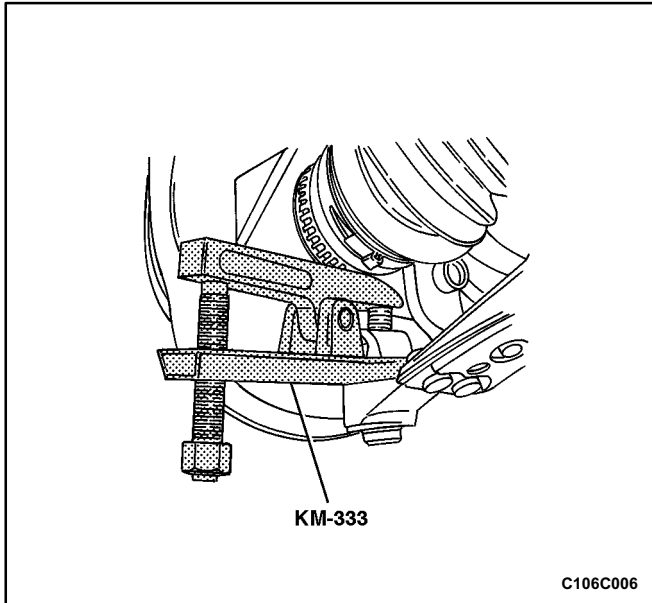

8. Separate the knuckle from the ball joint using the ball joint remover KM-333.

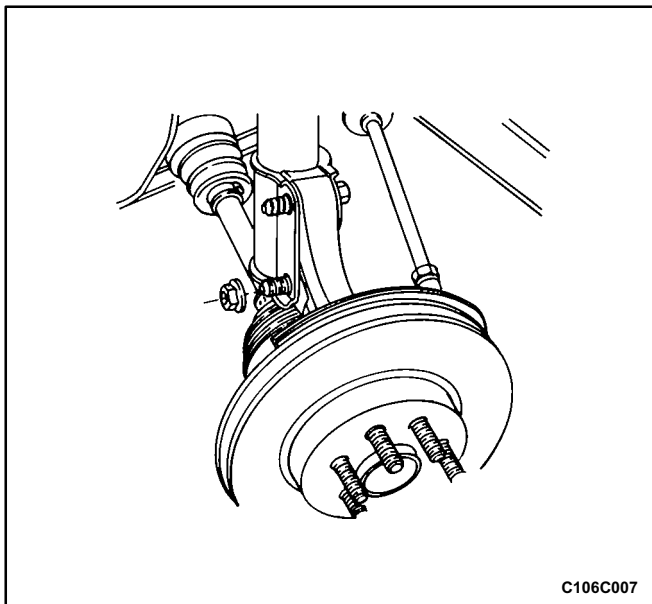

9. Remove the nuts from the bolts that connect the knuckle assembly to the strut assembly.

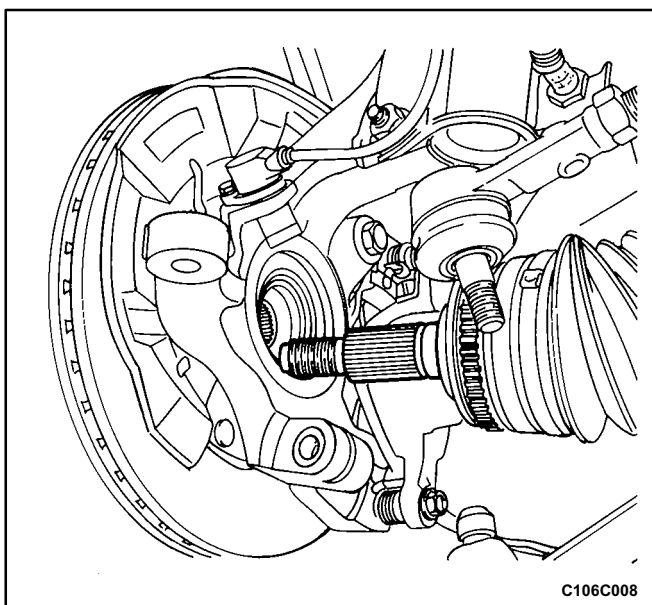

Notice: Do not overextend the axle joints. When either end of the shaft is disconnected, overextension of the joint can result in separation of internal components and possible joint failure. Use drive axle joint seal protectors whenever performing service on or near the drive axles. Failure to do so can cause internal joint or seal damage and result in possible joint failure.

10. Separate the drive axle shaft from the wheel hub.

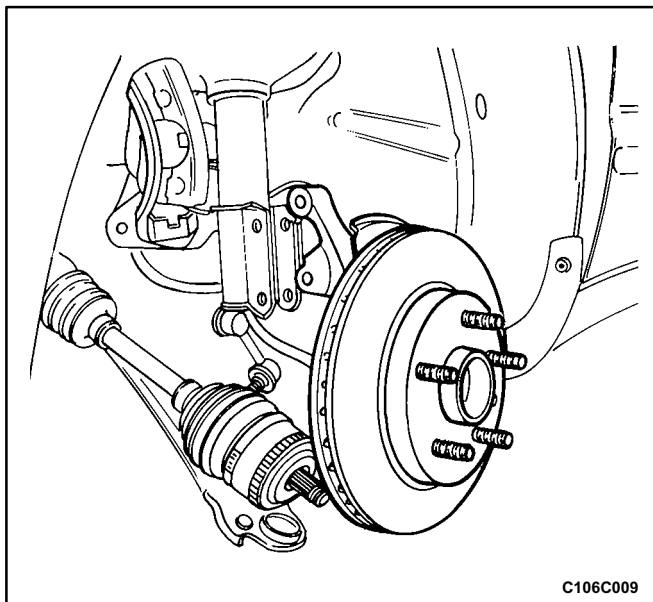

11. Support the drive axle.
12. Remove the bolts that connect the knuckle assembly to the strut assembly.
13. Remove the knuckle assembly from the vehicle.

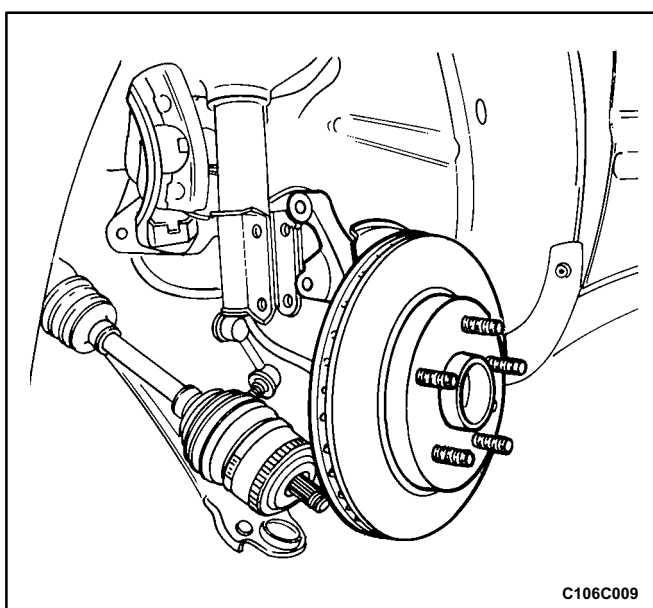

Installation Procedure

1. Install the knuckle assembly onto the vehicle.

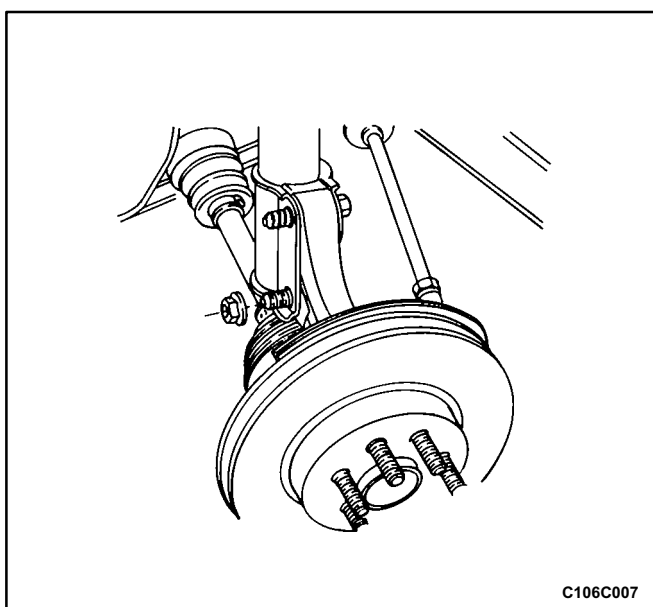

2. Install the steering knuckle to strut assembly nuts.

Tighten

Tighten the steering knuckle to strut assembly nuts to 135 N•m (100 lb•).

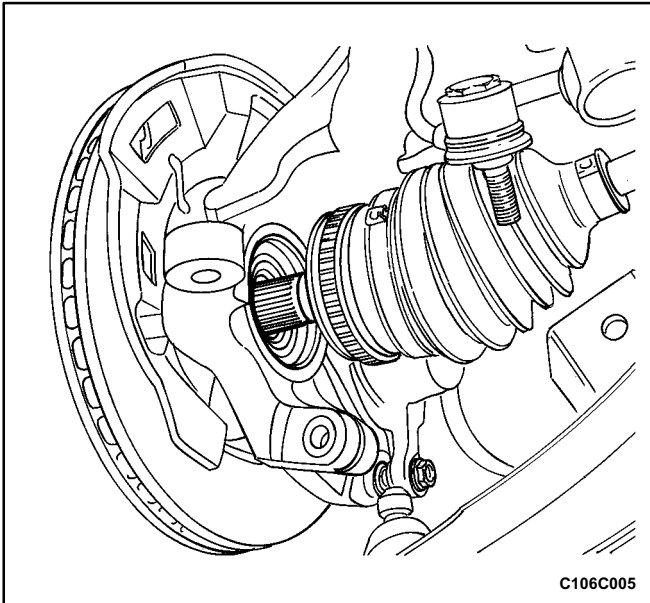

3. Connect the drive axle to the front wheel hub.

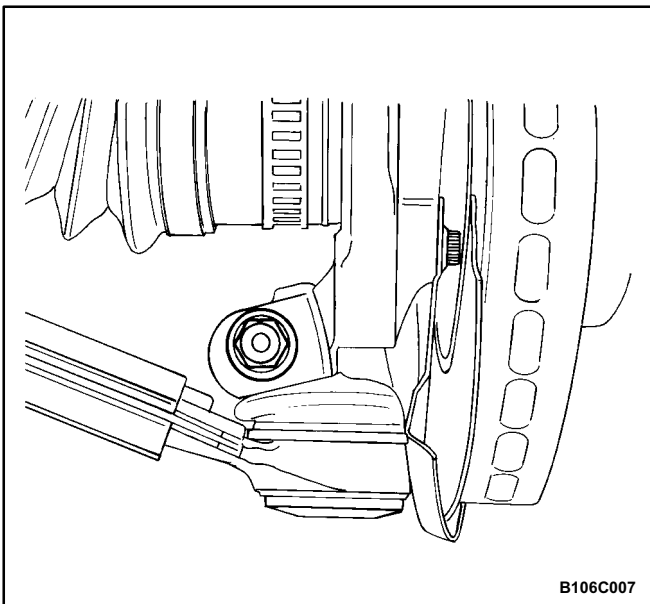

4. Connect the ball joint to the knuckle assembly.
5. Install the ball joint pinch bolt and the nut.

Tighten

Tighten the ball joint pinch bolt nut to 90 N•m (66 lb•ft).

6. Connect the ABS speed sensor electrical connection. Refer to *Section 4F, Antilock Brake System and Traction Control System*.

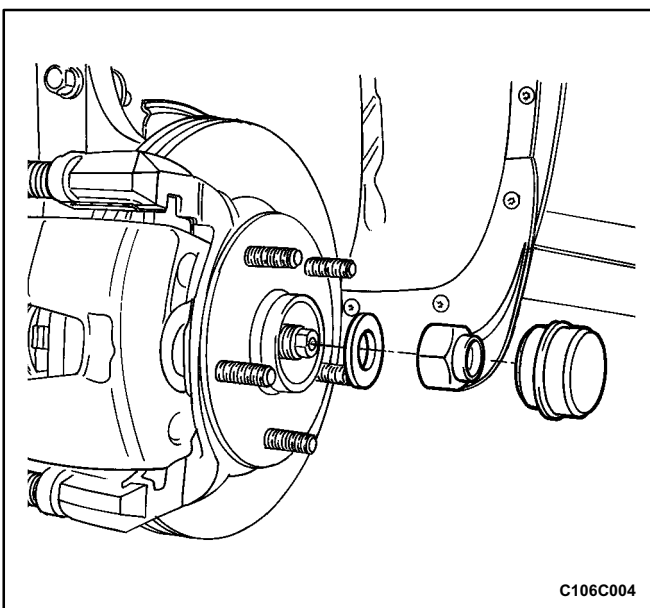

7. Connect the outer tie rod to the knuckle assembly. Refer to *Section 6C, Power Steering Gear*.
8. Install the brake caliper onto the rotor and the brake line onto the strut. Refer to *Section 4D, Front Disc Brakes*.
9. Install the washer and the caulking nut onto the axle shaft.

Tighten

Tighten the drive axle to hub caulking nut to 180 N•m (133 lb•ft). Loosen the nut, then retighten it to 50 N•m (37 lb•ft) plus 60 degrees.

10. Install the dust cap.
11. Install the wheel. Refer to *Section 2E, Tires and Wheels*.
12. Lower the vehicle.

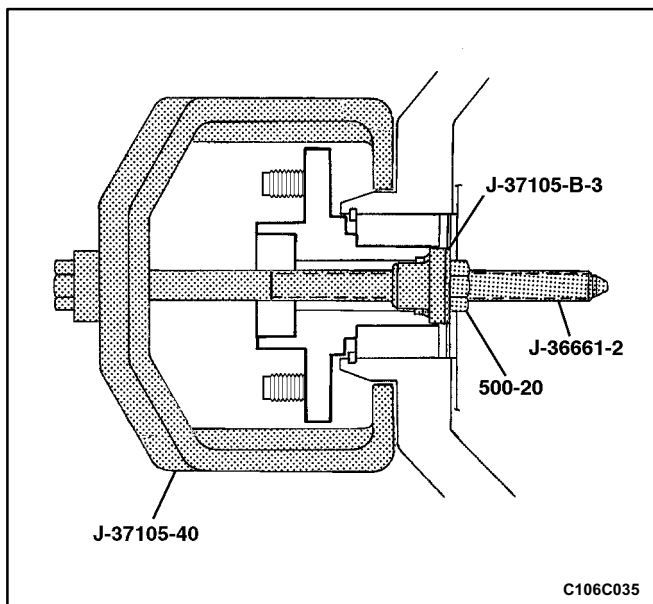

HUB AND BEARING

Tools Required

- 500-20 Hex Nut
- J-36661-2 Forcing Screw
- J-37105-40 Support Bridge
- J-37105-B-2 Bearing Adapter
- J-37105-B-3 Hub Adapter

Removal Procedure

1. Remove the drive axle from the front wheel hub. Refer to „Knuckle Assembly” in this section.
2. Remove the wheel hub with the support bridge J-37105-40, the hub adapter J-37105-B-3, the hex nut 500-20, and the forcing screw J-36661-2.

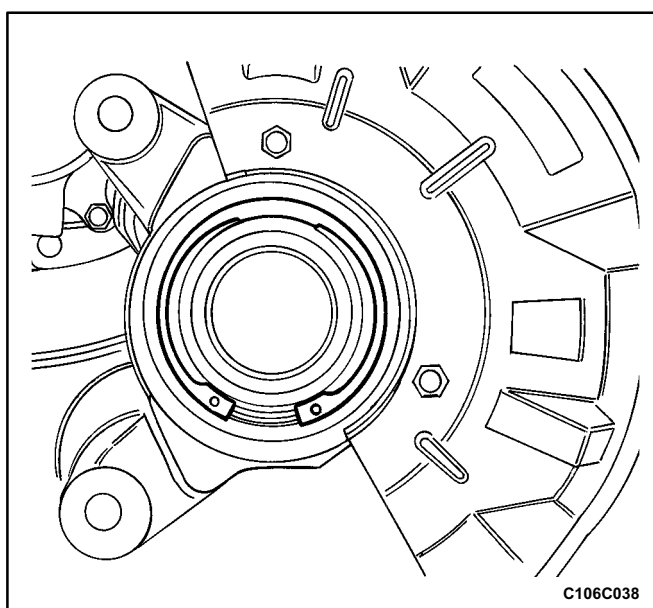

3. Remove the outer snap ring.

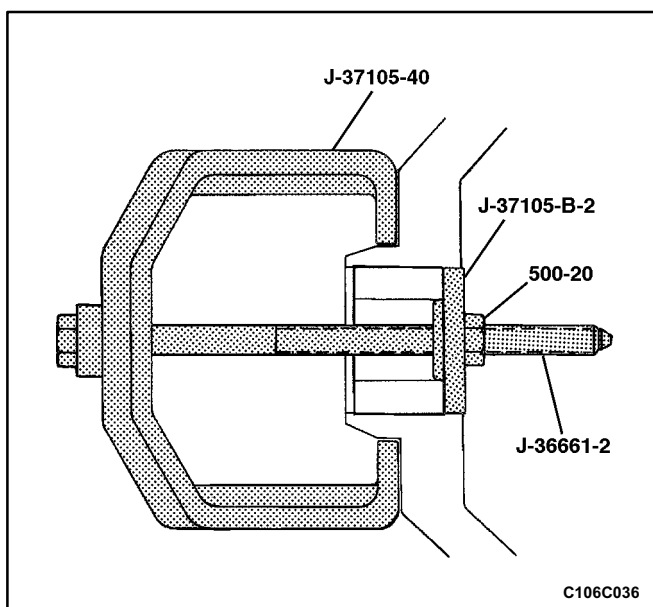

4. Remove the wheel bearing with the support bridge J-37105-40, the bearing adapter J-37105-B-2, the hex nut 500-20, and the forcing screw J-36661-2.
5. Clean the bore of the knuckle.

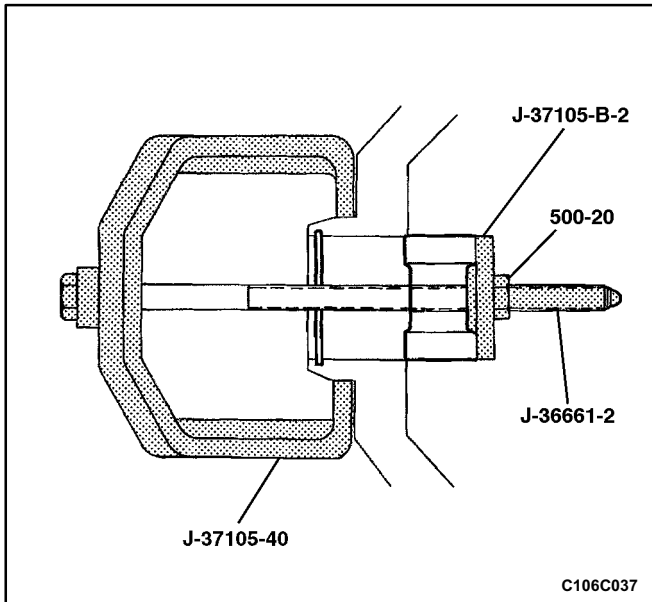

Installation Procedure

1. Install the outer snap ring and push the wheel bearing into place with the support bridge J-37105-40, the bearing adapter J-37105-B-2, the hex nut 500-20, and the forcing screw J-36661-2.

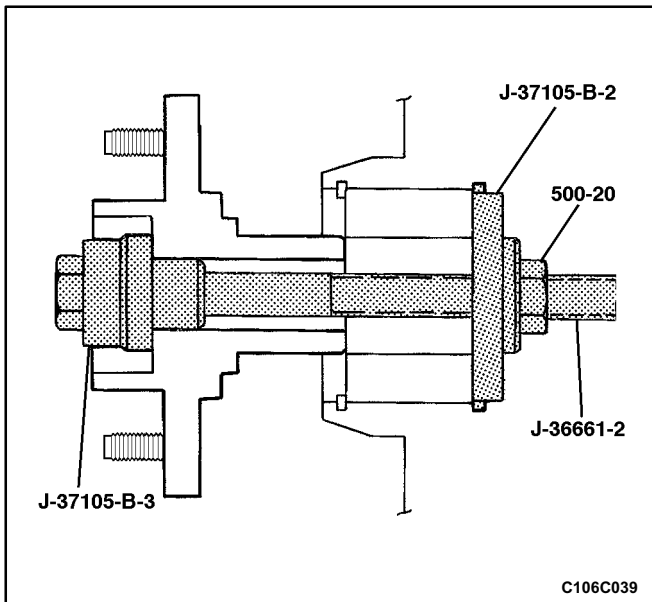

2. Push the wheel hub into place with the hub adapter J-37105-B-3, the bearing adapter J-37105-B-2, the hex nut 500-20, and the forcing screw J-36661-2.
3. Install the drive axle into the front wheel hub. Refer to „Knuckle Assembly” in this section.

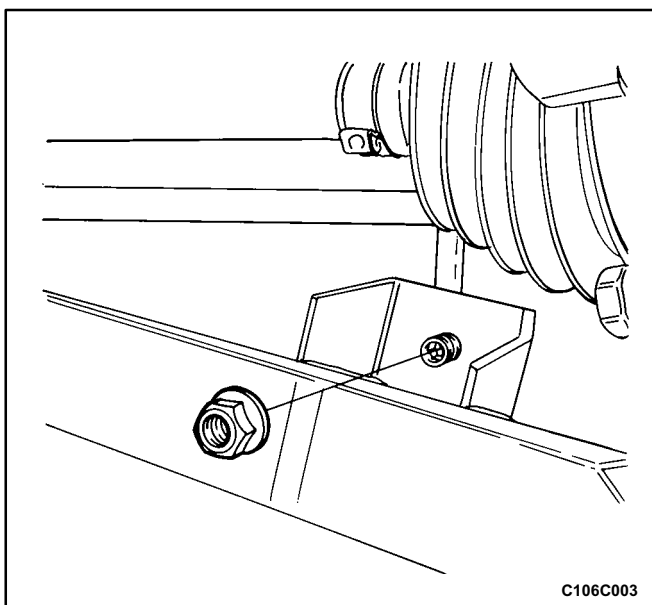

CONTROL ARM

Tools Required

KM-333 Ball Joint Remover

Removal Procedure

1. Raise and suitably support the vehicle. Let the control arms hang free.
2. Remove the wheel. Refer to *Section 2E, Tires and Wheels*.
3. Remove the stabilizer link-to-control arm nut and disconnect the stabilizer link from the control arm.

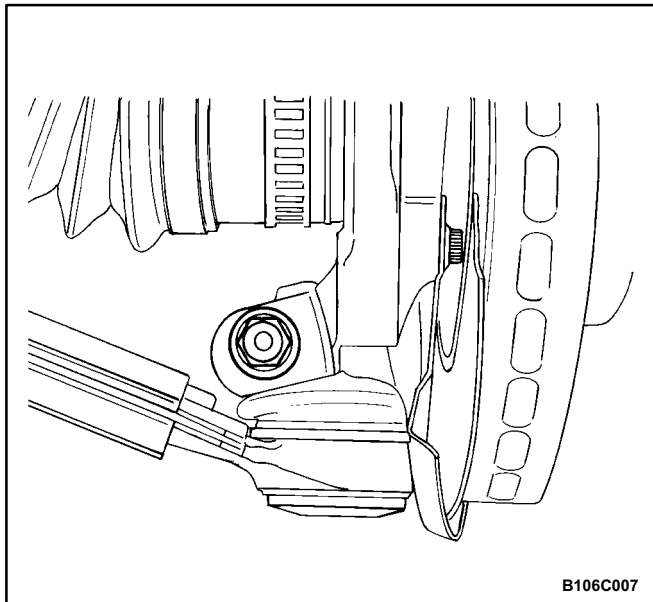

4. Remove the pinch bolt and the nut from the ball joint.

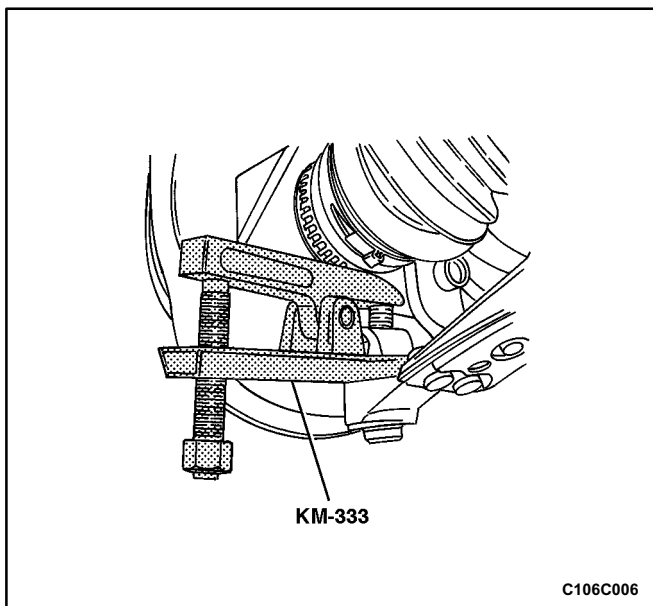

5. Disconnect the ball joint from the knuckle assembly using the ball joint remover KM-333.

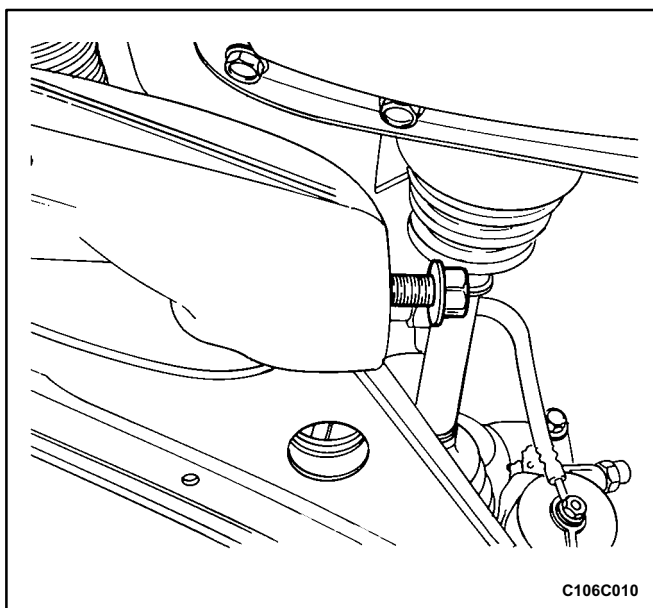

6. Remove the control arm to crossmember nut and the bolt.

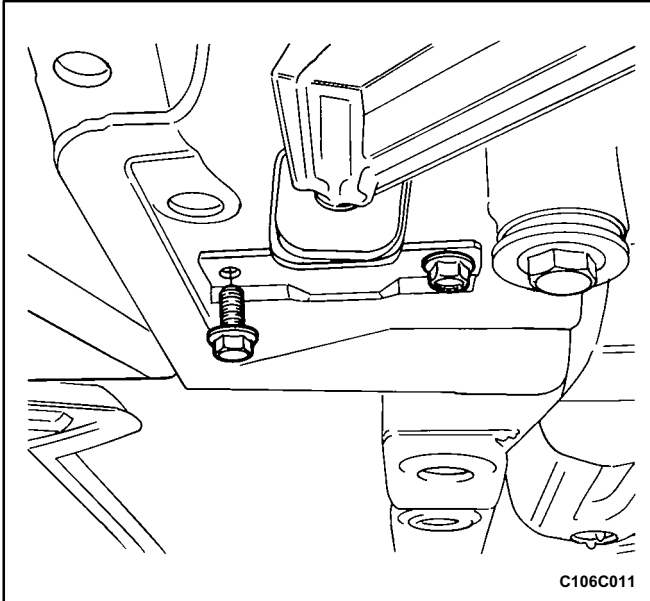

7. Remove the control arm rear bushing clamp bolts and clamp.
8. Remove the control arm from the vehicle.

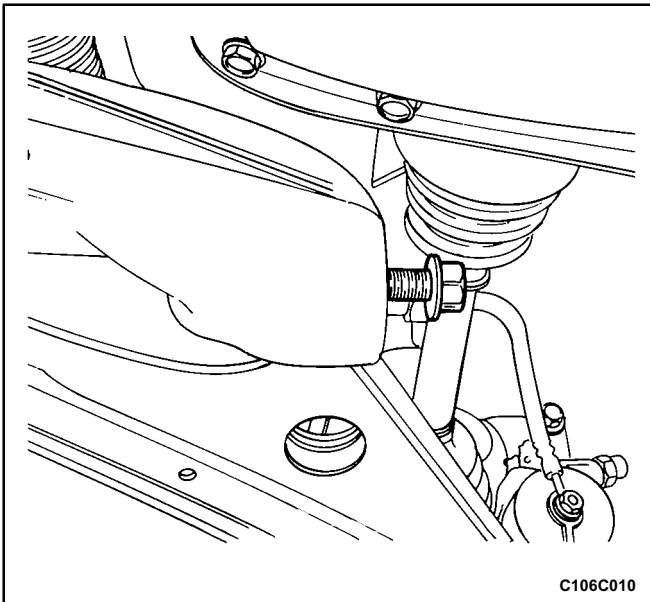

Installation Procedure

Important: The weight of the vehicle must be supported by the control arms before the control arm to crossmember and the control arm rear bushing clamp bolts are tightened. This can be done by lowering the vehicle onto jack stands under the control arms after the control arms have been installed.

1. Install the control arm.
2. Install the control arm to crossmember bolt and nut.
Do not tighten the bolt.
3. Install the control arm rear bushing clamp and bolts.
Do not tighten.

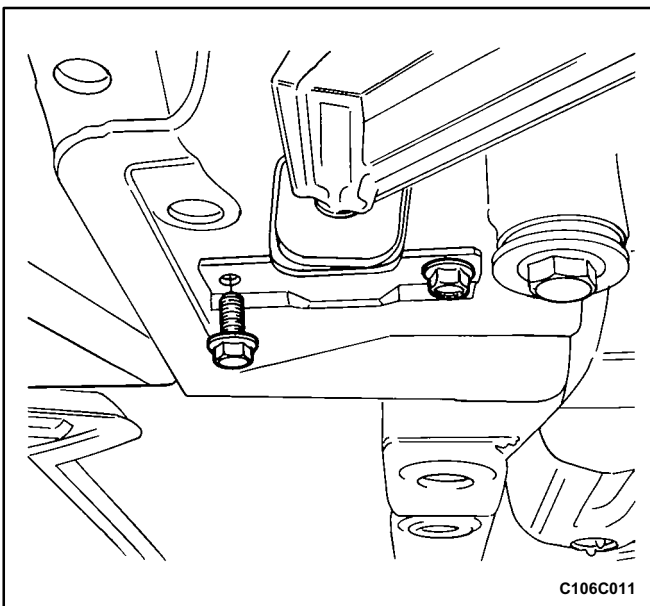

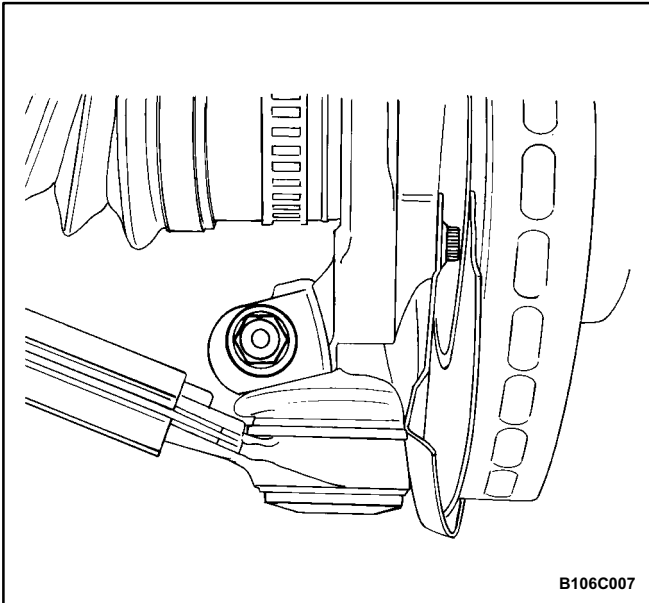

B106C007

4. Connect the ball joint to the steering knuckle and install the ball joint pinch bolt and the nut.

Tighten

Tighten the ball joint pinch bolt nut to 90 N•m (66 lb•ft).

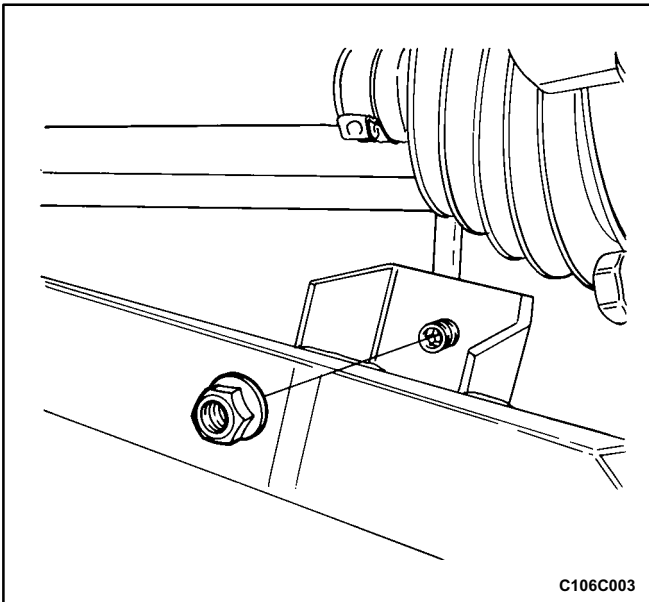

C106C003

5. Connect the stabilizer link to the control arm and install the stabilizer link to control arm nut.
6. Lower the vehicle so the control arms are supported by jack stands.

Tighten

Tighten the control arm rear bushing clamp bolts to 75 N•m (55 lb•ft).

Tighten the control arm front bushing nut to 140 N•m (103 lb•ft).

Tighten the stabilizer link to control arm nut to 45 N•m (33 lb•ft).

7. Raise the vehicle and install the wheel. Refer to *Section 2E, Tires and Wheels*.
8. Remove the jack stands and lower the vehicle.

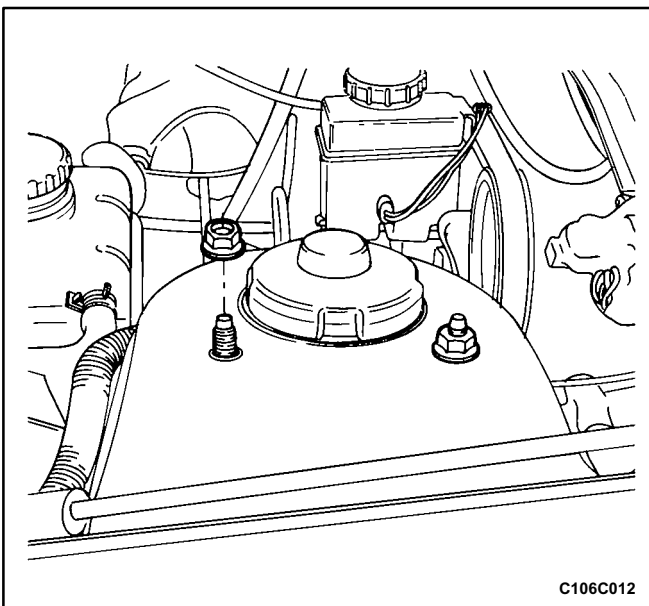

C106C012

STRUT ASSEMBLY

Removal Procedure

1. Remove the nuts that secure the strut assembly to the body of the vehicle.
2. Raise and suitably support the vehicle.
3. Remove the wheel. Refer to *Section 2E, Tires and Wheels*.
4. On vehicles equipped with an antilock braking system (ABS), disconnect the ABS sensor line from the strut assembly. Refer to *Section 4F, Antilock Brake System and Traction Control System*.
5. Remove the brake line from the securing bracket on the strut assembly. Refer to *Section 4E, Rear Brakes*.

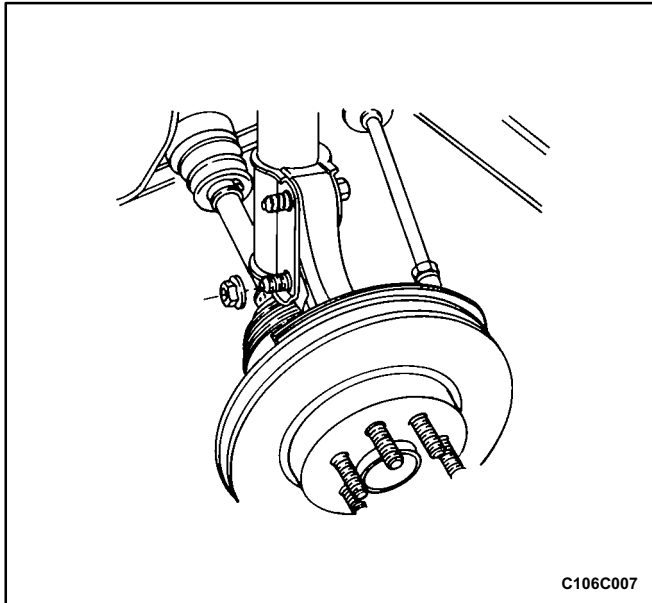

6. Disconnect the steering knuckle by removing the steering knuckle to strut assembly nuts and the bolts.

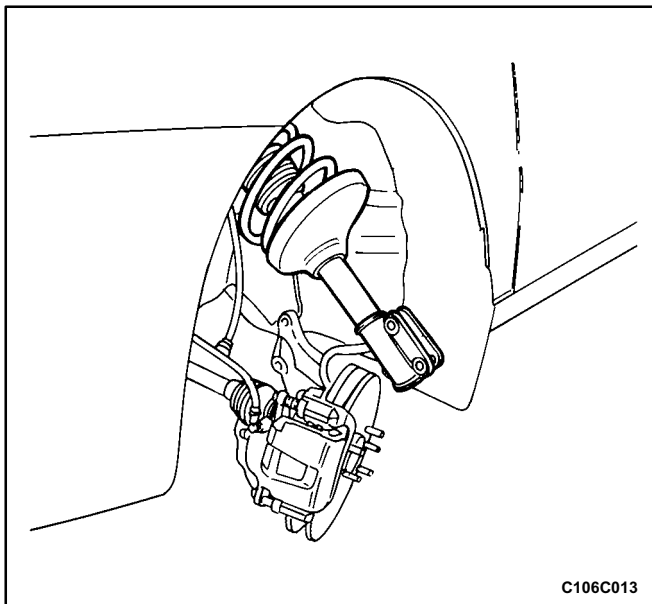

7. Remove the strut assembly.

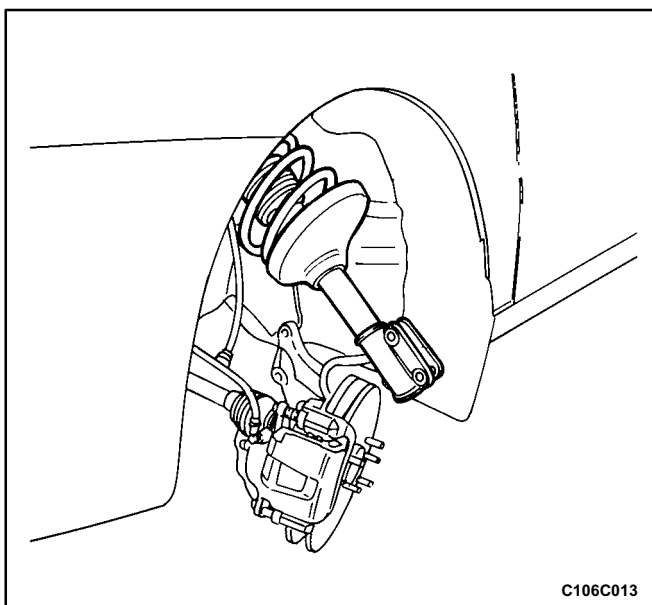

Installation Procedure

1. Install the strut assembly.

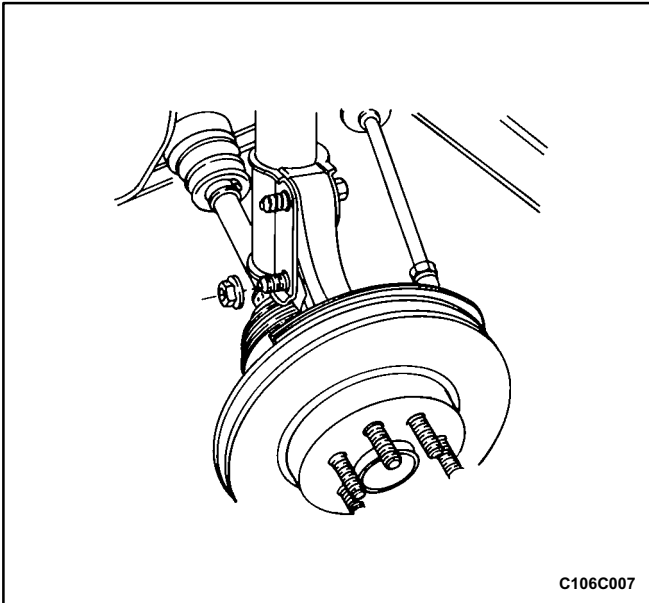

C106C007

2. Connect the strut assembly to the steering knuckle by installing the steering knuckle to strut assembly nuts and the bolts.

Tighten

Tighten the steering knuckle to strut assembly nuts and the bolts to 135 N•m (100 lb•ft).

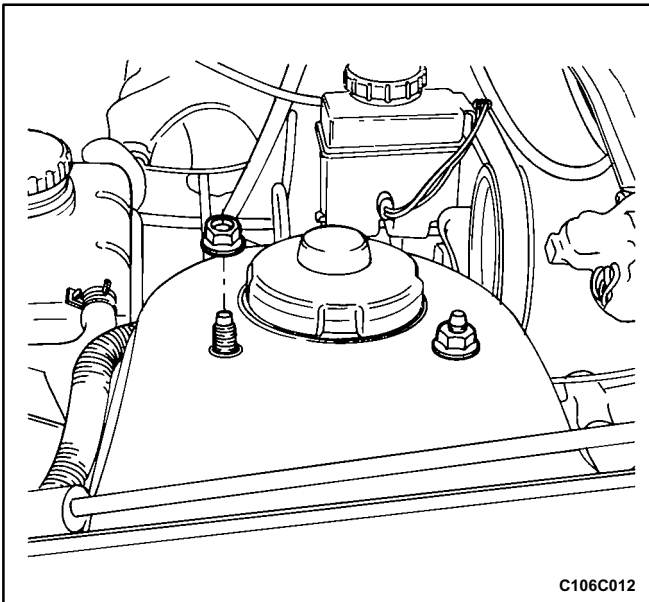

C106C012

3. Install the brake line to the securing bracket on the strut assembly. Refer to *Section 4E, Rear Brakes*.
4. On vehicles equipped with the ABS, connect the ABS sensor line to the strut assembly. Refer to *Section 4F, Antilock Brake System and Traction Control System*.
5. Install the wheel. Refer to *Section 2E, Tires and Wheels*.
6. Lower the vehicle.
7. Install the nuts securing the strut assembly to the body of the vehicle.

Tighten

Tighten the strut assembly to body nuts to 45 N•m (33 lb•ft).

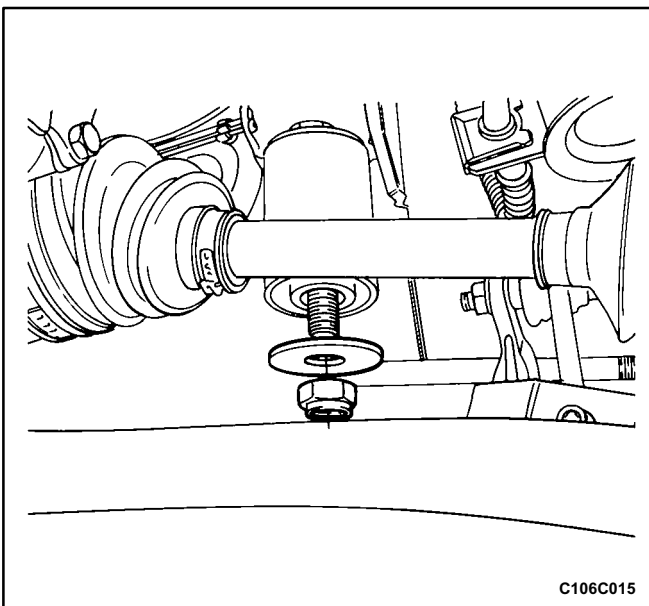

C106C015

CROSSMEMBER ASSEMBLY

Removal Procedure

1. Raise and suitably support the vehicle.
2. Remove the wheels. Refer to *Section 2E, Tires and Wheels*.
3. Remove the exhaust pipe forward of the catalytic converter. Refer to *Section 1G, Engine Exhaust*.
4. Remove the center member. Refer to *Section 9N, Frame and Underbody*.
5. Disconnect the control arms from the steering knuckle. Refer to „Control Arm” in this section.
6. Disconnect the power steering gear. Refer to *Section 6C, Power Steering Gear*.
7. Remove the crossmember to body front nuts and washers.

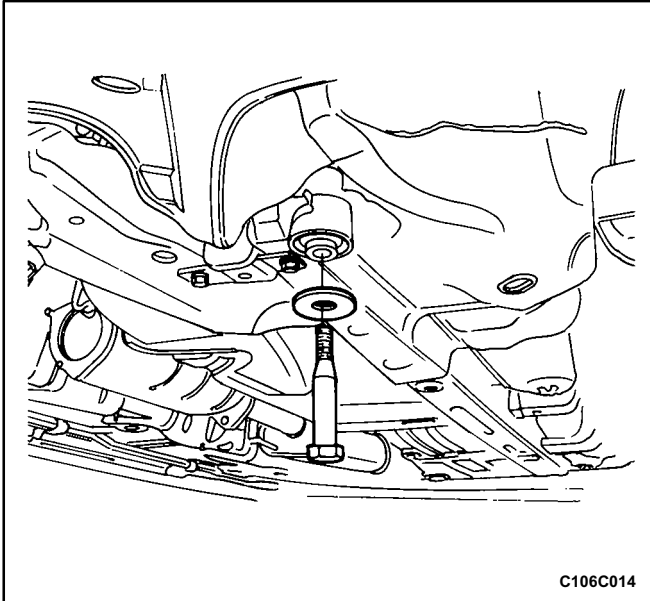

C106C014

Caution: Two technicians or jack stands must hold the front crossmember assembly during removal of the front attachment bolts. Failure to support the front crossmember properly can result in personal injury.

8. Support the crossmember and remove the crossmember to body rear bolts.
9. Remove the crossmember assembly from the vehicle.

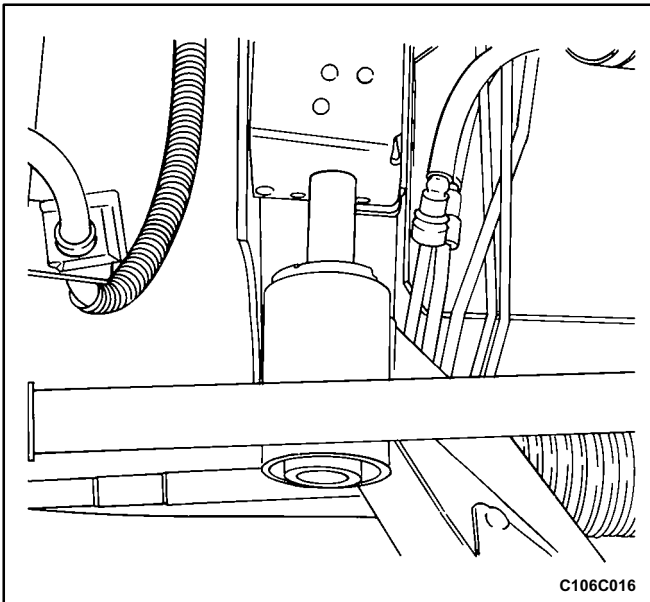

C106C016

Installation Procedure

1. Raise the crossmember and align the front attachment points with the body posts of the vehicle. Install the crossmember assembly.

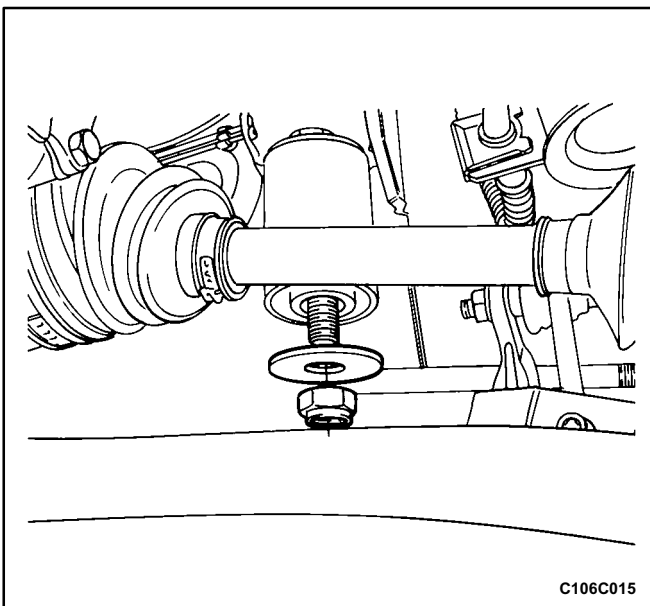

C106C015

2. Install the crossmember to body front nuts and washers.

Tighten

Tighten the crossmember to body front nuts to 145 N•m (107 lb•ft).

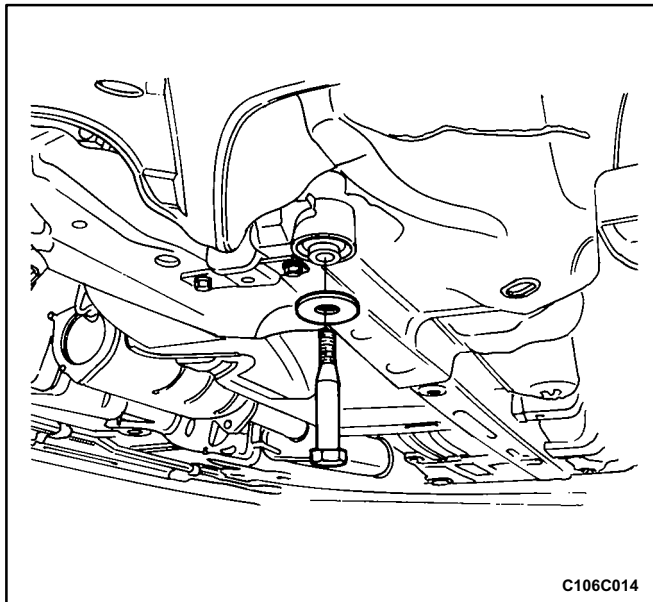

3. Install the crossmember to body rear bolts.

Tighten

Tighten the crossmember to body rear bolts to 145 N•m (107 lb•ft).

4. Connect the power steering gear. Refer to *Section 6C, Power Steering Gear*.
5. Connect the control arms to the steering knuckle. Refer to „Control Arm” in this section.
6. Install the center member. Refer to *Section 9N, Frame and Underbody*.
7. Install the exhaust pipe into the vehicle. Refer to *Section 1G, Engine Exhaust*.
8. Install the wheels. Refer to *Section 2E, Tires and Wheels*.
9. Lower the vehicle.

UNIT REPAIR

BALL JOINT

Disassembly Procedure

1. Remove the control arm. Refer to „Control Arm” in this section.
2. Drill off the heads of the three rivets with a 12 mm (0.47 inch) drill bit.
3. Punch out the rivets with a drift.

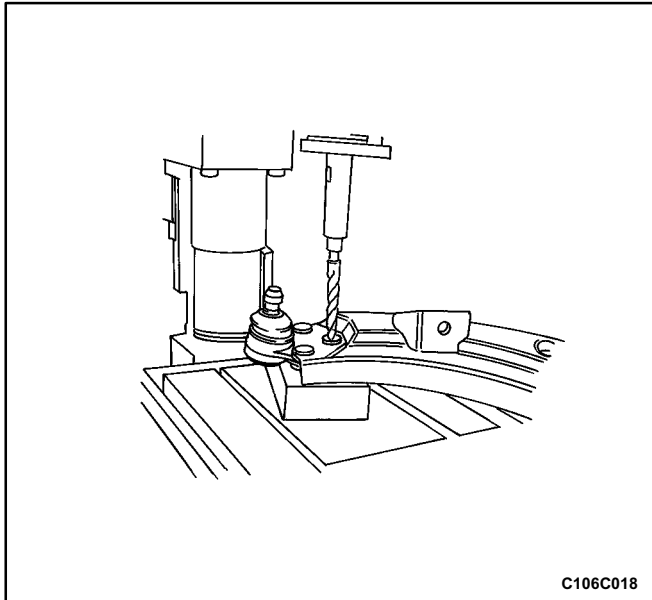

C106C018

Assembly Procedure

1. Connect the ball joint to the control arm by inserting three ball joint bolts from below the control arm.

Tighten

Tighten the ball joint to control arm nuts to 110 N•m (81 lb•ft).

2. Install the control arm. Refer to „Control Arm” in this section.

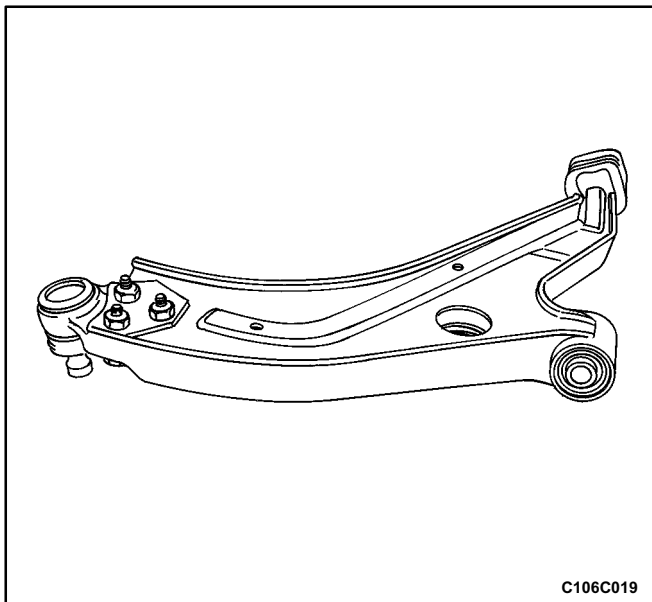

C106C019

CONTROL ARM BUSHINGS

Tools Required

KM-508-A Remover/Installer

KM-307-B Removal Plate

Disassembly Procedure

1. Remove the control arm. Refer to „Control Arm” in this section.
2. Remove the control arm rear bushing using a press, the removal plate KM-307-B, and a drift.

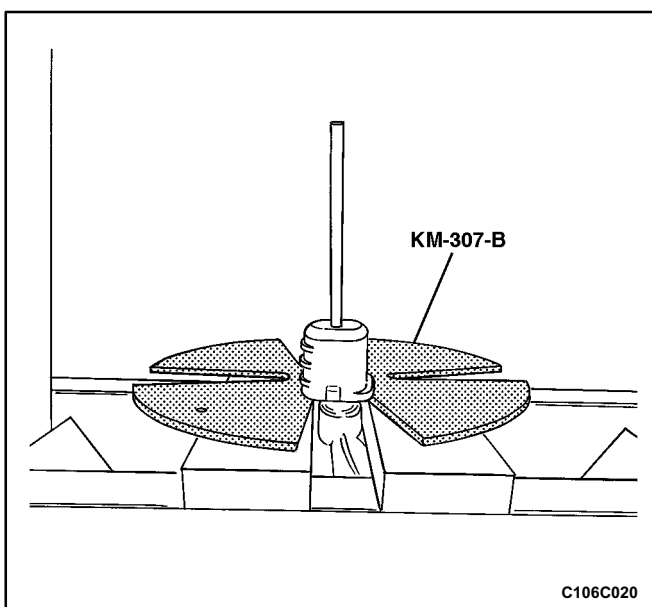

C106C020

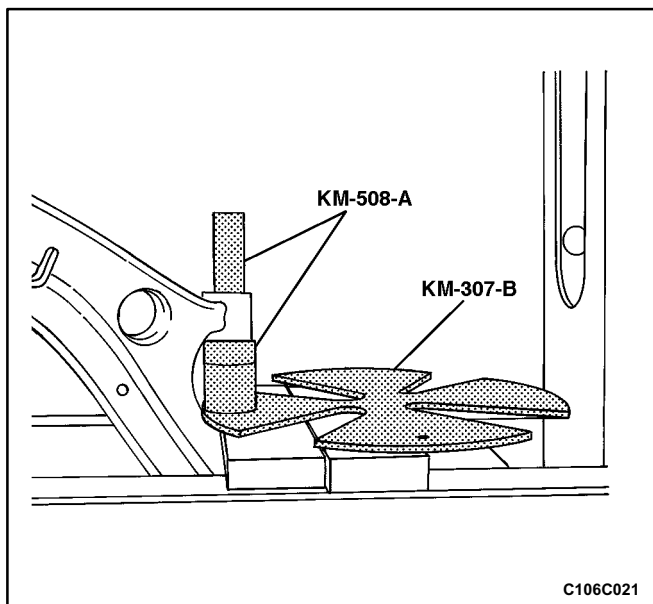

3. Remove the control arm front bushing using a press, the remover/installer KM-508-A, and the removal plate KM-307-B.

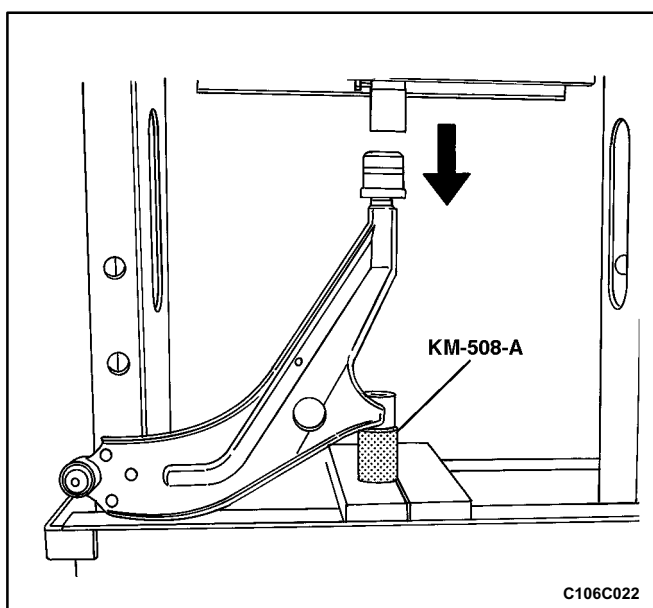

Assembly Procedure

1. Coat the control arm rear shaft with a multipurpose lubricant. Refer to *Section 1, General Information*.
2. Press the control arm rear bushing onto the shaft. Use the remover/installer KM-508-A to support the control arm.

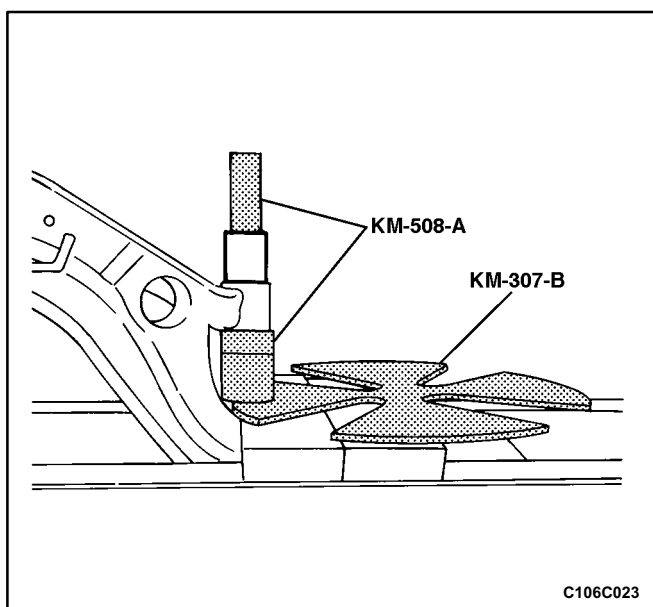

3. Coat the outside of the control arm front bushing and the inside of the control arm with a multipurpose lubricant. Refer to *Section 1, General Information*.
4. Press the control arm front bushing into the control arm using a press, the remover/installer KM-508-A and the removal plate KM-307-B. Center the bushing.
5. Install the control arm. Refer to „Control Arm” in this section.

FRONT STRUT ASSEMBLY

Tools Required

KM-329-A Spring Compressor

DV-005 Front Strut Mount Nut Wrench

Disassembly Procedure

1. Remove the strut assembly. Refer to „Strut Assembly” in this section.
2. Fasten the strut assembly to the spring compressor KM-329-A. Make sure the hooks are seated on the strut spring properly.

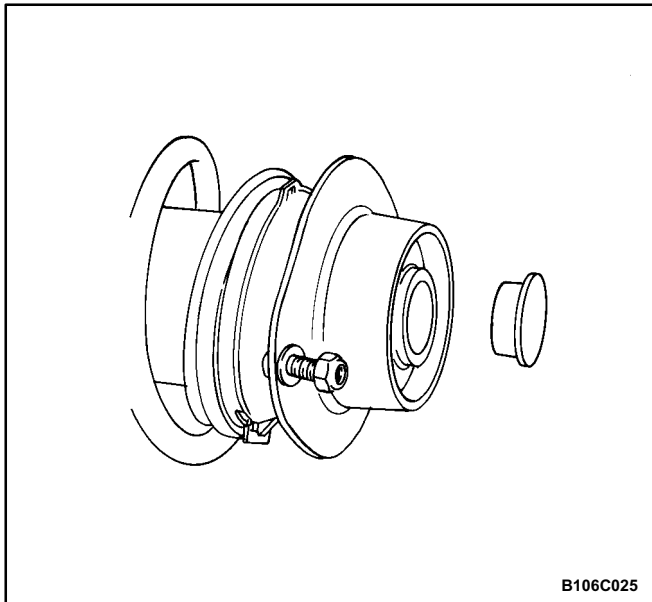
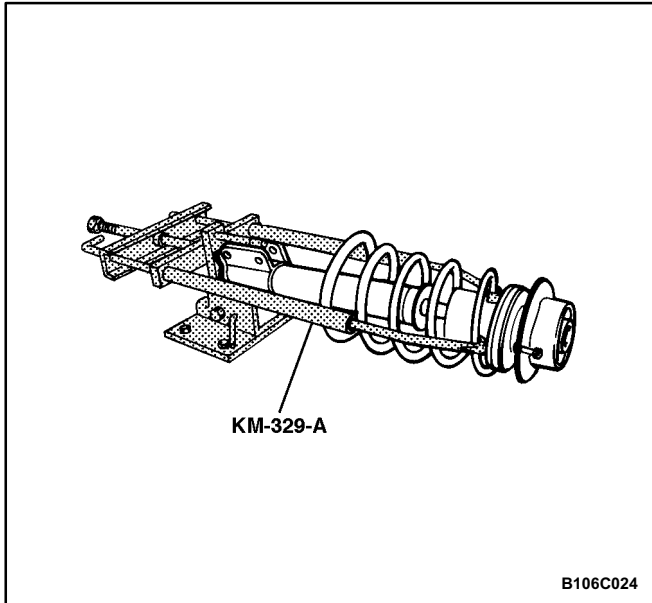

3. Compress the front spring with the spring compressor KM-329-A.
4. Remove the dust cover from the bearing assembly.

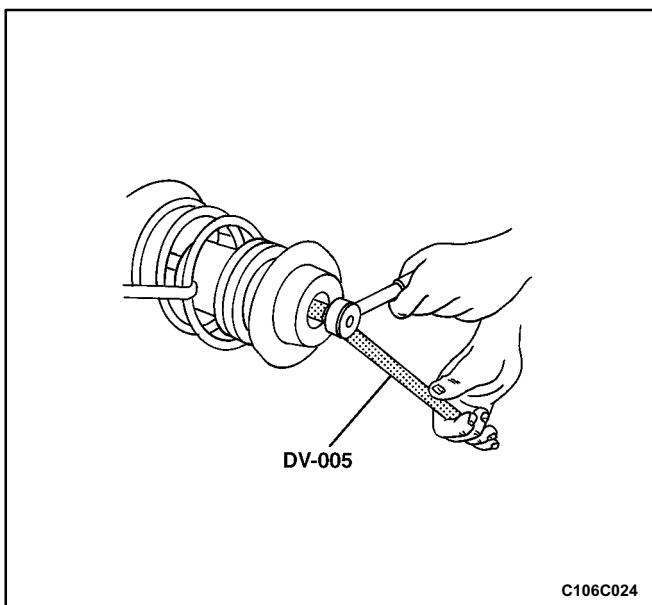

5. Use an open end wrench to hold the threaded piston rod while removing the piston rod nut with the front strut mount nut wrench DV-005.

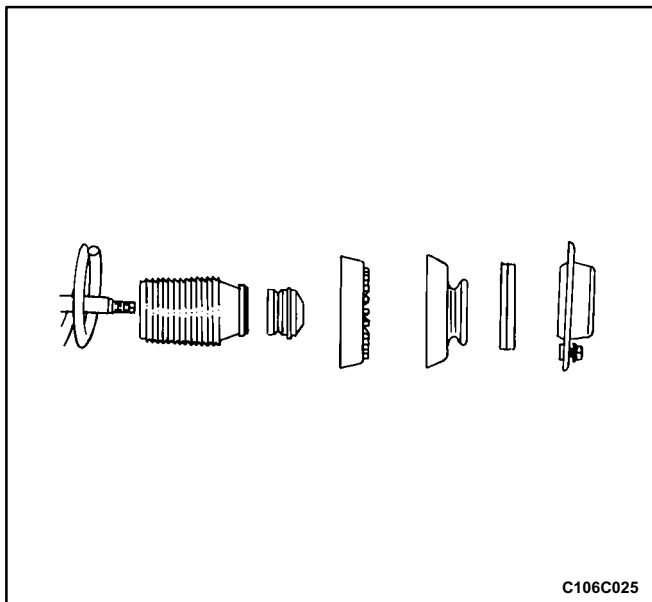

Important: Record the position of the front spring seat relative to the strut assembly to knuckle bracket. Place the front spring locator back in the same position during assembly.

6. Remove the upper strut mount, the mount bearing, the upper spring seat, the upper spring insulator, the hollow bumper and the piston rod boot.

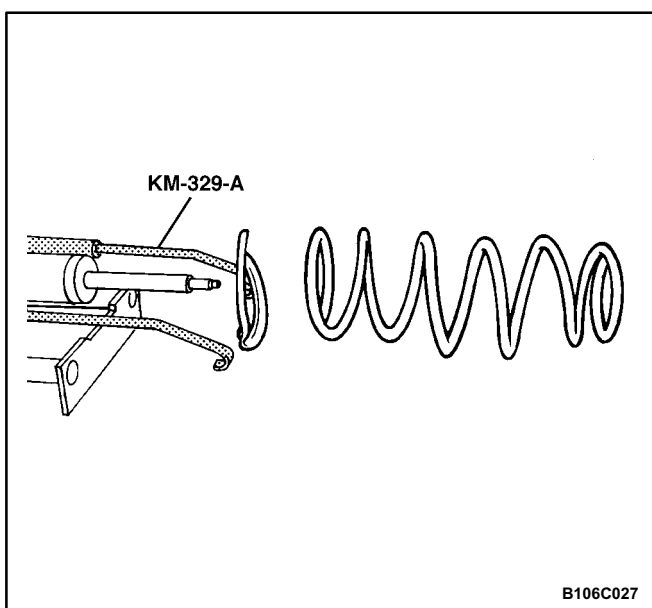

7. Release the spring.
8. Remove the spring and the lower spring insulator.

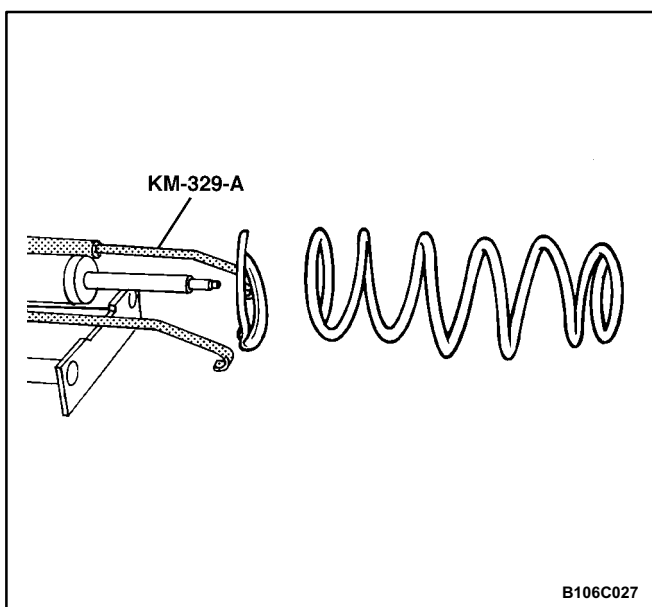

Assembly Procedure

1. Install the lower spring insulator and the spring.
2. Compress the spring using the spring compressor KM-329-A.

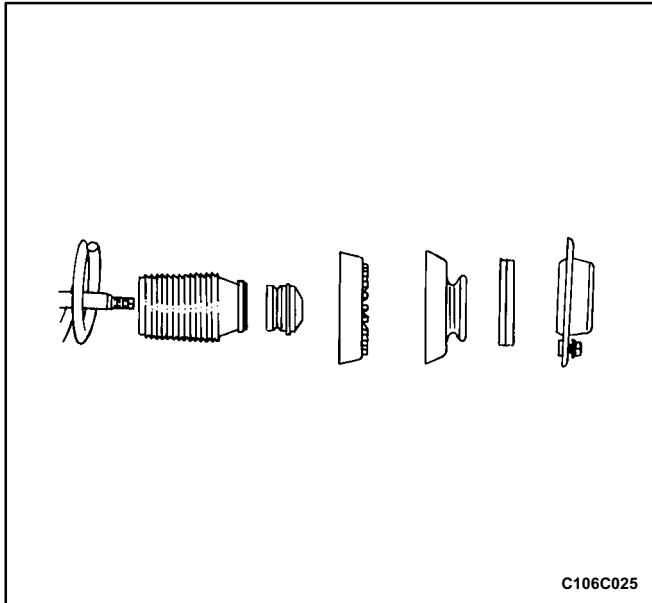

3. Install the piston rod boot, the hollow bumper, the upper spring insulator, the upper spring seat, the upper strut mount, and the mount bearing. Be sure the front spring seat is positioned correctly.

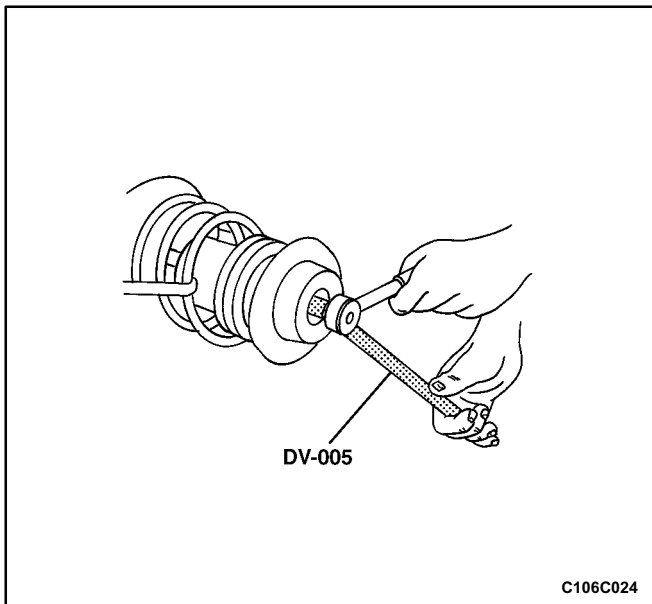

4. Install the piston rod nut with the front strut mount nut wrench DV-005.

Tighten

Tighten the piston rod nut to 70 N•m (52 lb•ft).

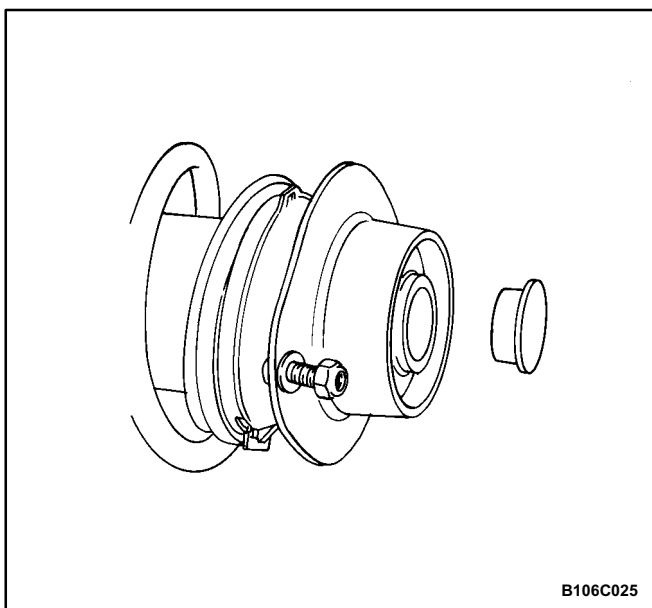

5. Install the dust cover to the bearing assembly.
6. Release the spring compressor KM-329-A.
7. Remove the strut assembly from the spring compressor KM-329-A.
8. Install the strut assembly onto the vehicle. Refer to „Strut Assembly” in this section.

KNUCKLE

Disassembly Procedure

1. Remove the knuckle assembly from the vehicle. Refer to „Knuckle Assembly” in this section.
2. Remove the rotor. Refer to *Section 4D, Front Disc Brakes*.
3. Remove the hub and bearing assembly. Refer to „Hub and Bearing” in this section.
4. Remove the brake splash shield. Refer to *Section 4D, Front Disc Brakes*.

Assembly Procedure

1. Install the brake splash shield. Refer to *Section 4D, Front Disc Brakes*.
2. Install the hub and bearing assembly. Refer to „Hub and Bearing” in this section.
3. Install the rotor. Refer to *Section 4D, Front Disc Brakes*.
4. Install the knuckle assembly onto the vehicle. Refer to „Knuckle Assembly” in this section.

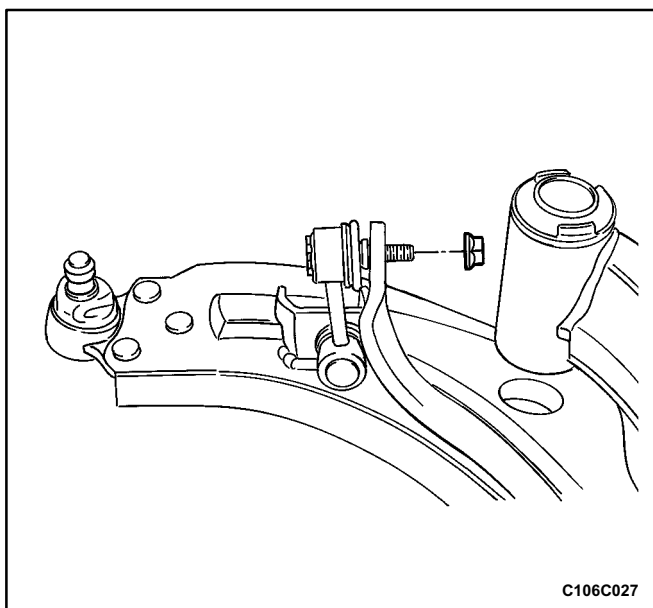
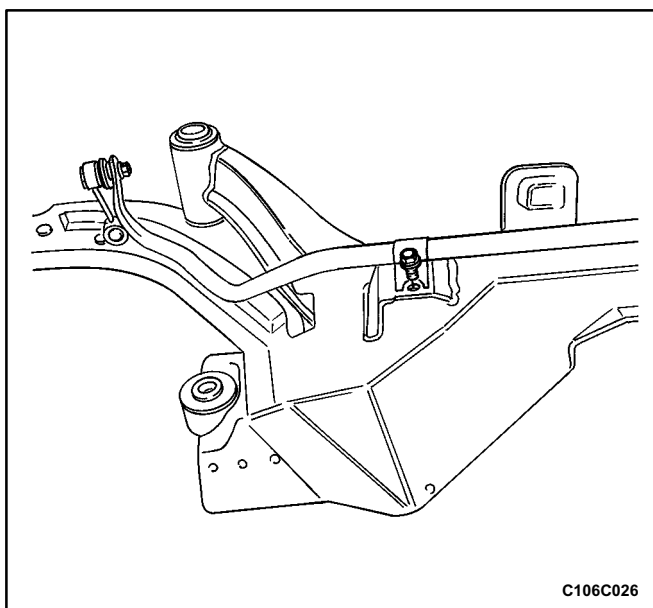

CROSSMEMBER

Disassembly Procedure

1. Remove the crossmember assembly from the vehicle. Refer to „Crossmember Assembly” in this section.
2. Remove the stabilizer clamp bolts.
3. Remove the stabilizer shaft to stabilizer link nuts.
4. Remove the stabilizer shaft clamps, insulators and stabilizer shaft from the crossmember.

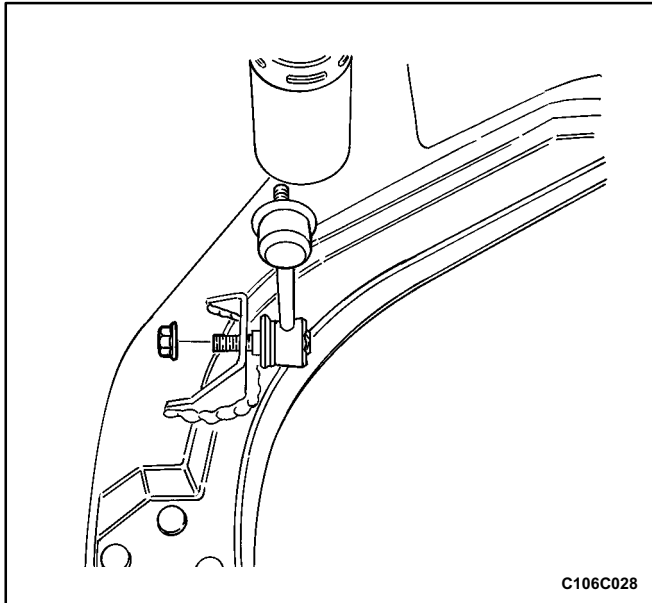

5. Remove the stabilizer link to control arm nut.
6. Remove the stabilizer link.

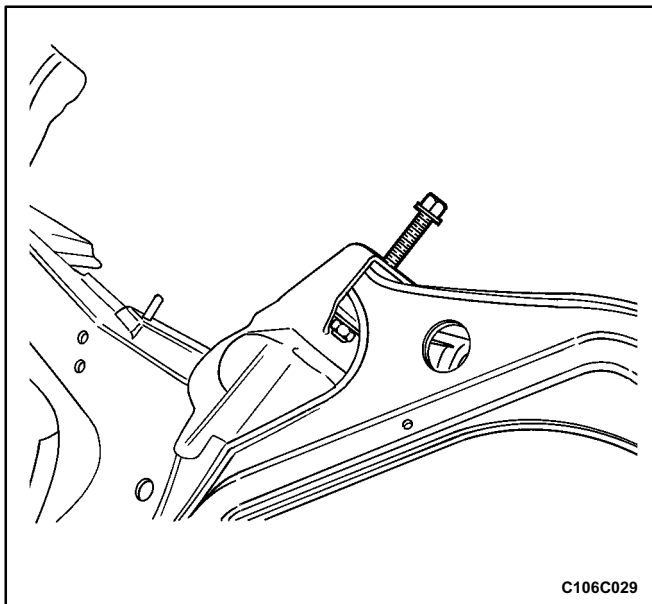

7. Remove the control arm front nuts and bolts.

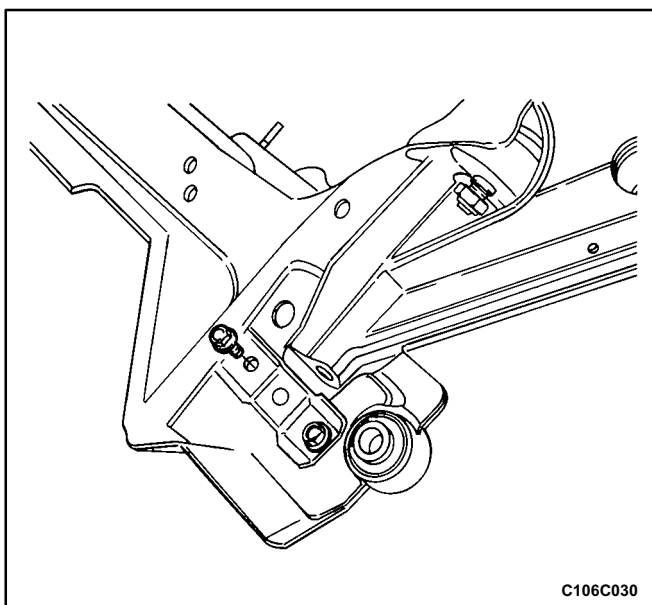

8. Remove the control arm rear bushing clamp bolts and clamps.
9. Remove the control arms.

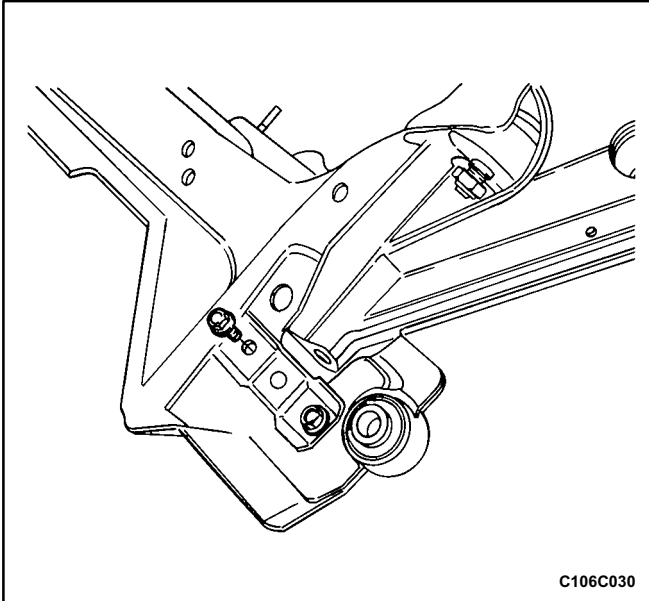

Assembly Procedure

Important: The weight of the vehicle must be supported by the control arms before the stabilizer link to control arm nut, the stabilizer shaft to stabilizer link nut and the control arm front nut and rear bolts are tightened. This can be done by lowering the vehicle onto jack stands under the control arms.

1. Install the control arms.
2. Install the control arm rear bushing clamps and clamp bolts. Do not tighten.

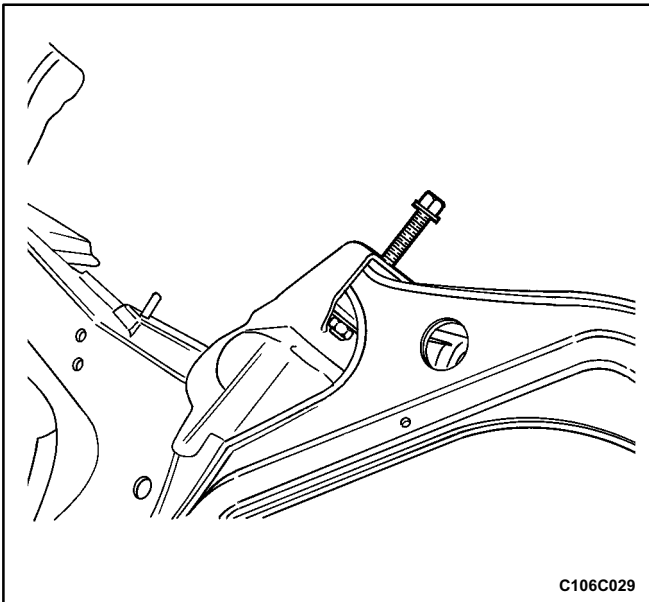

3. Install the control arm front nuts and bolts. Do not tighten.

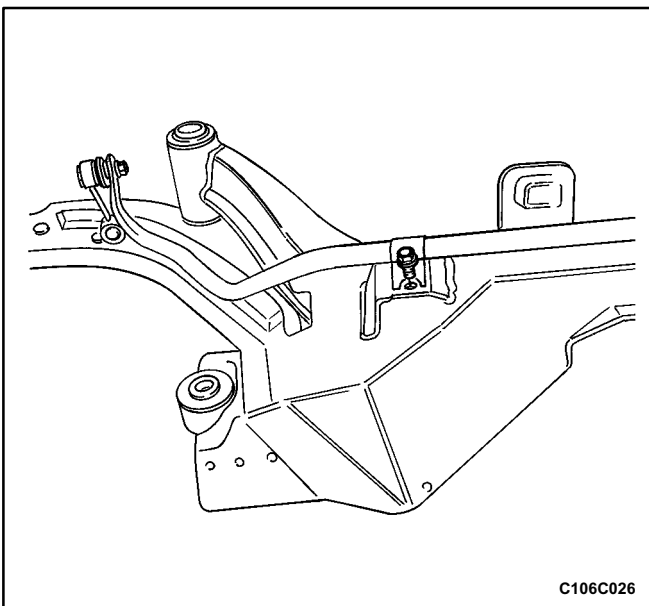

4. Install the stabilizer clamps, the stabilizer shaft, and the insulators.
5. Install the stabilizer shaft to crossmember clamp bolts.

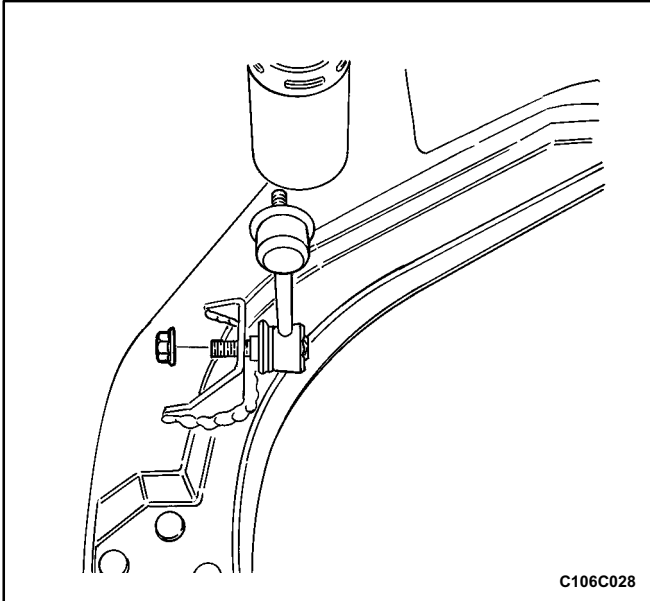

6. Install the stabilizer link.
7. Install the stabilizer link to control arm nuts. Do not tighten.

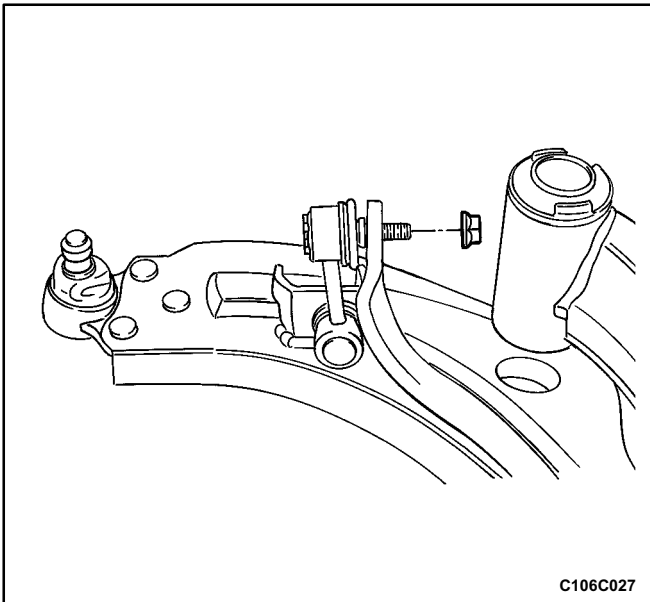

8. Install the stabilizer shaft to stabilizer link nuts. Do not tighten.

Tighten

Tighten the stabilizer shaft to crossmember clamp bolts to 37 N•m (27 lb•ft).

9. Install the crossmember assembly into the vehicle. Refer to „Crossmember Assembly” in this section.
10. Lower the vehicle so the control arms are supported by jack stands.

Tighten

Tighten the control arm rear bushing clamp bolts to 75 N•m (55 lb•ft).

Tighten the control arm front bushing nuts to 140 N•m (103 lb•ft).

Tighten the stabilizer link to control arm nuts to 45 N•m (33 lb•ft).

Tighten the stabilizer shaft to stabilizer link nuts to 45 N•m (33 lb•ft).

11. Remove the jack stands and lower the vehicle.

GENERAL DESCRIPTION AND SYSTEM OPERATION

FRONT SUSPENSION

The front suspension for this vehicle is a combination a strut assembly and a knuckle assembly. The strut assembly combines a strut dampener and spring mounted to the body of the vehicle. The upper end of the strut is isolated by a rubber mount and contains a bearing to allow the strut to turn. The knuckle is attached to the strut assembly and pivots on a ball joint bolted to the control arm. The control arms pivot from the body using rubber bushings.

The ball joint is fastened to the steering knuckle with a pinch bolt and nut, and to the lower control arm with rivets. The stabilizer bar interconnects both strut assemblies of the vehicle through the stabilizer link and is attached to the front suspension crossmember. Jounce and rebound movements affecting one wheel are partially transmitted to the opposite wheel of the vehicle to stabilize body roll.

When servicing the control arm to body attachment and the stabilizer shaft to body insulators, make sure the attaching bolts are loose until the control arms are moved to the trim height, which is curb height. Trim height is the normal position to which the control arms move when the vehicle is sitting on the ground. Refer to „General Specifications” in this section.